

# TYPE EV-0630F

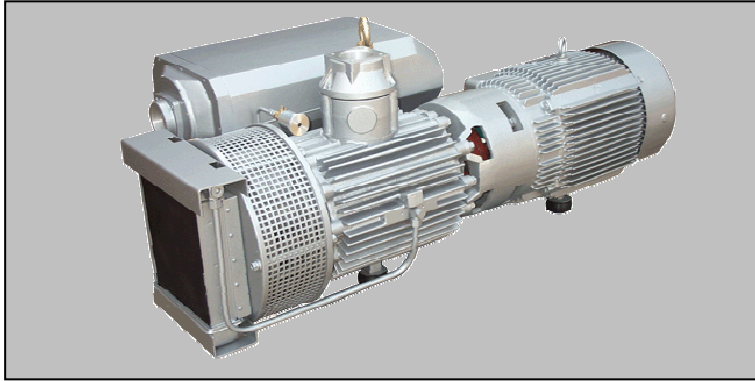

**Pumping speed curve**

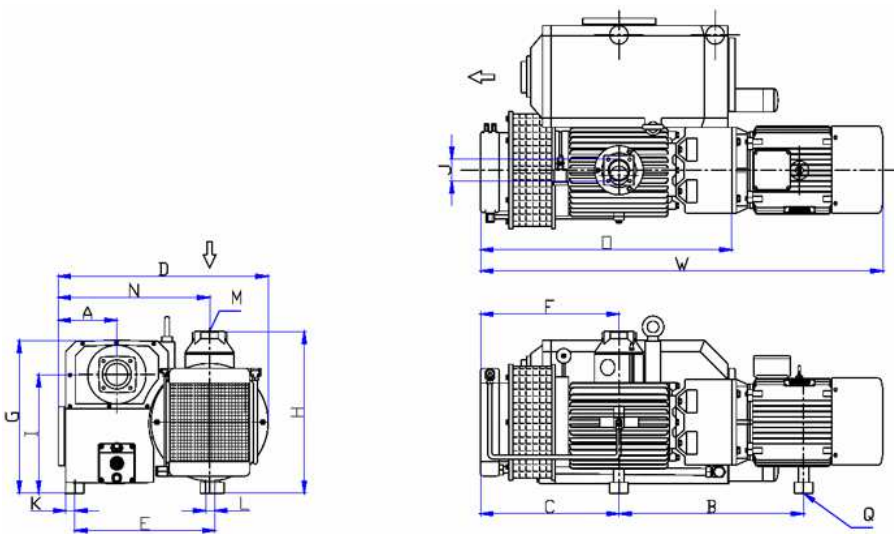
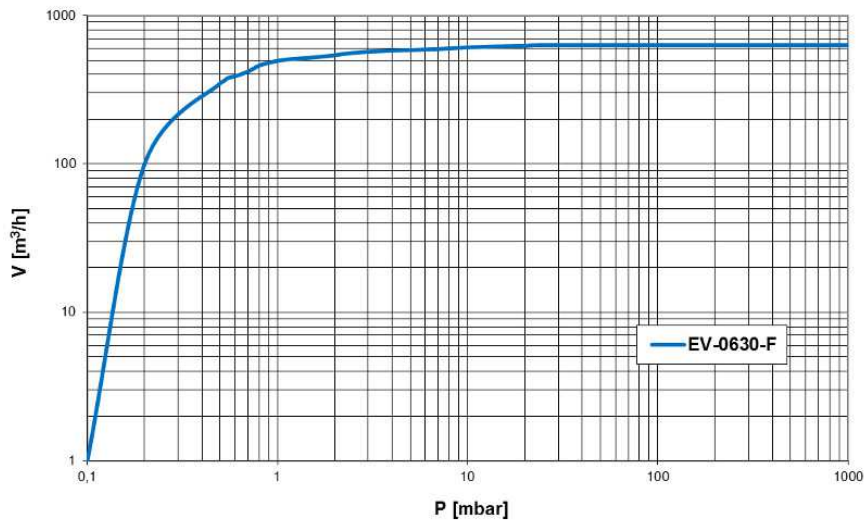

Dimensions	W	D	H	A	B	C	E	F	G	I	J	K	L	M	N	O	Q
EV-0630F	1650	860	600	240	757	567	575	567	625	485	G 3"	37	37	G 3"	620	1050	3x M12

## TYPE EV-0630F

Technical Data			TYPE EV-0630F	
			50 Hz	60 Hz
Nominal displacement	m <sup>3</sup> /h	630	780	
Ultimate pressure F type	mbar	< 0,1	< 0,1	
Motor power	kW	15,0	18,5	
Nominal speed	rpm	980	1160	
Noise level	dB(A)	77	79	
Operating temperature	°C	80	80	
Water vapor tolerance	mbar	40	40	
Water vapor capacity	l/h	27	30	
Oil capacity	ltr	19	19	
Weight	kg	582	703	
Admissible ambient temp.	°C	10 to 40	10 to 40	
Connection	Inlet	G(BSP)	3"	3"
	Outlet	G(BSP)	3"	3"

Ordering Information	TYPE EV-0630F	
	50 Hz	60 Hz
<b>Three phase motor</b> 400V, 50Hz (IE2) 400V, 60Hz (IE2)	114001	114002
Other Voltages/Frequencies	Upon request	
Filling with special oil	Upon request	
Exhaust filter cartridge	8x 120120A	
Service kit	120499	
Overhaul kit	120500	
Pump module	120900	
Inlet dust filter, paper cartridge	120800	