

OPERATING MANUAL

jnb80e1-h (1011) Translation of the original manual

Catalog-No.

550-300

550-310

550-330



from software version 1.7

Modul1000

Modular Leak Detector

Legal notice
INFICON GmbH
Bonner Straße 498
50968 Cologne
Germany

Copyright© 2010 INFICON GmbH, Cologne. This document may only be reproduced
in any form with the permission of INFICON GmbH, Cologne.

Content

| | | |
|----------|---------------------------------------|------------|
| 1 | Operating instructions | 1-5 |
| 1.1 | How to use this manual | 1-5 |
| 1.2 | Warning and danger symbols | 1-5 |
| 1.3 | Graphic conventions | 1-6 |
| 1.4 | Definition of Terms | 1-6 |
| 2 | Important safety instructions | 2-1 |
| 2.1 | Intended use | 2-1 |
| 2.2 | User requirements | 2-1 |
| 2.3 | Restrictions of use | 2-2 |
| 2.4 | Hazards in the event of intended use | 2-2 |
| 3 | Description of equipment | 3-1 |
| 3.1 | The housing | 3-1 |
| 3.2 | Interfaces | 3-3 |
| 3.3 | Operating options | 3-3 |
| 3.3.1 | Desktop operation | 3-4 |
| 3.3.2 | Installation in switch cabinet | 3-4 |
| 3.3.3 | Remote control RC1000 | 3-5 |
| 3.4 | Scope of delivery | 3-6 |
| 3.5 | Accessories | 3-6 |
| 3.5.1 | Sniffer line SL200 | 3-6 |
| 3.5.2 | Test chamber TC1000 | 3-6 |
| 3.5.3 | Set of male connectors for Interfaces | 3-7 |
| 4 | Installation | 4-1 |
| 4.1 | Mechanical Installation | 4-1 |
| 4.2 | Electrical installation | 4-1 |
| 4.2.1 | Mains socket | 4-1 |
| 4.2.2 | Electrical interfaces | 4-2 |
| 4.2.3 | Vacuum connections | 4-6 |
| 5 | Working Modes | 5-1 |
| 5.1 | Vacuum | 5-1 |
| 5.2 | Partial Flow Mode | 5-2 |
| 5.3 | Auto Leak Test | 5-3 |
| 5.3.1 | Auto Leak Test Settings | 5-3 |
| 5.4 | Commander mode | 5-4 |
| 5.4.1 | Design of a leak detector system | 5-5 |
| 5.4.2 | Test sequence of events | 5-6 |
| 5.5 | Sniff mode tips | 5-8 |

| | | |
|----------|---|------------|
| 6 | Operation | 6-1 |
| 6.1 | Switching ON | 6-1 |
| 6.2 | Status LED | 6-1 |
| 6.3 | Control | 6-2 |
| 6.4 | Control commands | 6-3 |
| 6.5 | Display | 6-6 |
| 6.6 | Calibration in Vacuum mode | 6-9 |
| 6.7 | Calibration in Sniff mode | 6-10 |
| 6.8 | Calibration in Auto Leak Test | 6-11 |
| 6.9 | Calibration in Commander mode | 6-11 |
| 6.10 | Machine factor | 6-12 |
| 6.11 | Menu structure | 6-13 |
| 6.12 | Explanation of Menu Items | 6-15 |
| 6.12.1 | Main menu → Return | 6-15 |
| 6.12.2 | Main menu → View | 6-15 |
| 6.12.3 | Main menu → Mode | 6-16 |
| 6.12.4 | Main menu → Trigger & Alarms | 6-16 |
| 6.12.5 | Main Menu → Calibration (CAL) Mode Vacuum | 6-18 |
| 6.12.6 | Main menu → Settings | 6-20 |
| 6.12.6.1 | Main menu → Settings → Vacuum settings | 6-20 |
| 6.12.6.2 | Main menu → Settings → Zero & Background | 6-23 |
| 6.12.6.3 | Main menu → Settings → Mass | 6-23 |
| 6.12.6.4 | Main menu → Settings → Interfaces | 6-23 |
| 6.12.6.5 | Main menu → Settings → Miscellaneous | 6-26 |
| 6.12.6.6 | Main menu → Settings → Load/Save Parameters | 6-27 |
| 6.12.6.7 | Main menu → Settings → Monitoring | 6-28 |
| 6.12.7 | Main menu → Info | 6-30 |
| 6.12.8 | Main menu → Access Control | 6-31 |
| 7 | Maintenance tasks | 7-1 |
| 7.1 | Maintenance and service at INFICON | 7-1 |
| 7.2 | General Maintenance Instructions | 7-1 |
| 7.3 | Maintenance schedule | 7-3 |
| 7.4 | Maintenance intervals | 7-3 |
| 7.5 | Description of the maintenance work | 7-5 |
| 7.5.1 | Opening of the Device | 7-6 |
| 7.6 | TMH 071 Replace the Lubricant Reservoir | 7-7 |
| 7.7 | Fuse replacement | 7-10 |
| 7.7.1 | Overview on Electrical Fuses | 7-10 |
| 7.7.2 | Replace mains fuse | 7-11 |
| 7.7.3 | Replace fuses on interface board | 7-12 |
| 7.8 | Replacing of parameter memory (I•STICK) | 7-13 |
| 7.9 | Replace Vent Filter | 7-14 |

| | | |
|-------|---|------|
| 8 | Transport and disposal | 8-1 |
| 8.1 | Transporting after Contamination | 8-1 |
| 8.2 | Disposal | 8-2 |
| 9 | Technical Data | 9-1 |
| 9.1 | Technical data of components | 9-1 |
| 9.1.1 | Power supply | 9-1 |
| 9.1.2 | Weight / dimensions | 9-1 |
| 9.1.3 | Characteristics | 9-1 |
| 9.1.4 | Environmental Conditions | 9-2 |
| 9.2 | Control via the PLC inputs and outputs | 9-3 |
| 9.2.1 | PLC inputs | 9-3 |
| 9.2.2 | PLC Outputs | 9-6 |
| 9.3 | The digital valve outputs | 9-9 |
| 9.4 | Analogue Output | 9-10 |
| 9.4.1 | Configuration of the analogue outputs | 9-10 |
| 9.5 | Pin Assignments | 9-13 |
| 9.5.1 | PLC IN / AUDIO | 9-13 |
| 9.5.2 | PLC OUT | 9-15 |
| 9.5.3 | Pressure Gauge | 9-16 |
| 9.5.4 | Valves | 9-19 |
| 9.5.5 | Recorder | 9-21 |
| 9.6 | Installation diagram of the control unit for rackinstallation | 9-22 |
| 9.7 | Commander mode | 9-23 |
| 9.8 | CE-Certificate | 9-24 |
| 10 | Error Messages and Warnings | 10-1 |
| 11 | Ordering Information | 11-1 |
| 11.1 | Service Centres World Wide | 11-3 |
| <hr/> | | |
| | INDEX | 11-5 |

1 Operating instructions

1.1 How to use this manual

- Read this manual before using Modul1000.
- Keep the manual so that you can use it anytime.
- Enclose the operating manual if the device is ever passed on to third parties.

1.2 Warning and danger symbols



Danger

This symbol refers to an *immediate* hazard, which may result in *fatal or serious injuries* (crippling).



Warning

This symbol refers to a *possibly hazardous* situation, which may result in *fatal or serious injuries*.



Caution

This symbol refers to a *possibly hazardous* situation, which may result in *slight injuries*.

This symbol is also used to alert you to the risk of *material or environmental damage*.

1.3 Graphic conventions

Notice: Points to very useful pieces of information.

- 1 Points to an operation that you have to perform.
 - ⇒ Points to the result of an operation you accomplished.
 - Points to the button you have to press.
- Shows a listing.

1.4 Definition of Terms

Autotune / Mass alignment

The Modul1000 adjusts its tuning voltage to determine the optimal voltage for peak efficiency.

Autoranging

The range of the pre-amplifier is selected automatically. The Autoranging feature of the Modul1000 covers the entire range or leak rates depending on the selected operating mode. Vacuum mode or Sniff mode Not only the leak rate signal, but also the pressure in the test sample (inlet pressure PE) and the fore-vacuum pressure (PV) are used for control purposes.

Auto zero

Determination and automatic adaptation of the helium background in the Vacuum mode. Through this function, the internal zero level of the instrument is determined which is then subtracted from the current leak rate signal. This function is run during the calibration process or when operating the start push-button, provided the Modul1000 has been running previously for at least 20 seconds in the Standby or Vent mode. If the helium background previously suppressed should drop, the zero level will be adapted automatically.

Fore pressure

Fore pressure between turbo pump and fore pressure pump.

Internal helium background

The existing helium partial pressure in the measurement system. The level of the internal helium background is measured in the Stand-by mode and subtracted from the measured signal. (see above: Auto zero)

Minimum detectable leak rate

The smallest leak rate the Modul1000 is able to detect.
(5×10^{-12} mbar l/s).

Menu

The menu allows the user to program the Modul1000 according to the requirements.
The menu has a tree structure.

As-delivered condition

The default settings of the Modul1000 are as delivered by the factory.

Standby

The Modul1000 is ready for operation.

MEASURE

MEASURE mode is when the Modul1000 has achieved a pressure better than the crossover and the unit is sampling the gas load for helium leak rate.

2 Important safety instructions

2.1 Intended use

The Modul1000 is intended to be used for the leak test under vacuum. With the sniffer version of Modul1000 (Catalogue-No. 550-310), it is also possible to locate leaks in the test sample.

The Modul1000 may only be used for leak tests with helium and hydrogen. It may only be used in dry rooms and on dry surfaces.

Only use INFICON accessories.

The intended use includes:

- the compliance with the technical data and the ambient conditions,
- the use of standard and original accessories,
- consideration of this documentation and the observation of the included instructions and directives.

2.2 User requirements

The Modul1000 must only be connected and operated by properly trained staff.

- Get used to the functioning of the device. Only connect and operate the device after reading and understanding the manual.
- Consult local, State, and national agencies regarding specific requirements and regulations.
- Address any further safety, operation and / or maintenance questions to our nearest office.

2.3 Restrictions of use

 **Danger**

Danger of fatal injuries due to explosion.
Switch on and operate the Modul1000 only outside of explosive areas.

 **Danger**

Risk of dangerous gases.
The device is not suitable for caustic, toxic and explosive substances.
Only use this device for detecting harmless substances.

2.4 Hazards in the event of intended use

Before installing the Modul1000, carefully read all safety instructions and make sure that you have properly understood them.

Danger

 **Danger**

Danger of fatal injuries due to explosion.
When explosive gases are used as test gas, the gas container could explode.
Avoid flames and sparks, keep ignition sources far away from the device.

 **Danger**

Danger of fatal injuries due to electric shock.
Keep the sniffer tip away from live parts.

 **Danger**

Danger of fatal injuries due to electric shock!
Connect the Modul1000 properly with the 3-core power cable and then connect the PE-line to earth.

**Danger**

Danger of fatal injuries due to electric shock!

Disconnect the Modul1000 from the power supply before the you open it.

**Danger**

Risk of injury and contamination caused by toxic gases.

Only use the Modul1000 for detecting harmless substances.

The device is not suitable for toxic, caustic, micro-biologic, explosive, radioactive or other hazardous substances.

Contact the manufacturer if you plan to use the device for such substances.

**Danger**

Danger of fatal injuries due to implosion.

Components which are not pressure-resistant, can burst cause through implosion.

Only connect containers and parts to the inlet flange of Modul1000 which are suitable for vacuum.

**Danger**

Danger of fatal injuries due to strong permanent magnets.

Magnets can impact the functioning of pacemakers.

If you wear a pacemaker, keep away from the device as far as it is specified in the manufacturer's instructions.

Warning



Warning

Risk of injuries through rotating parts

Before a transport leave the Modul1000 switched off for at least 20 minutes.



Warning

Danger of injury through dropping devices.

Two people should carry the Modul1000 or use a lifting device.



Warning

Back injury through heavy loads.

Two people should carry the Modul1000 or use a lifting device.



Warning

Injury to health due to emissions and fumes of oil-sealed pumps.

Before it is operated in closed rooms, the oil sealed fore-pressure pump, if used, has to be connected to an exhaust gas pipe.



Warning

Danger of fatal injuries due to electric shock!

Only operate the Modul1000 in buildings and on dry surfaces.



Warning

Risk of injury due to sucking inlet flange

If the vacuum function of the Modul1000 is activated, body parts which are close to the inlet flange can be sucked in.

Keep your body away from the inlet flange.

**Warning**

Supposed risk

If it can be supposed that safe operation is not ensured any more, the device must be switched off and must be secured against accidental switching on.
If this happens, contact the INFICON service people.

Notice: Such a problem could occur,

- when the device has visible damages,
- when liquid has penetrated into the device,
- when the device does not operate any more,
- after long storage time under unfavourable conditions,
- after strong transport conditions

Caution



Caution

The Modul1000 is destroyed by aggressive substances.

Avoid contact to bases, acids, solvents and do not expose it to extreme climatic conditions.



Caution

The Modul1000 may be damaged by improper transport conditions.

Only use this device for detecting helium and hydrogen.

Use a filter in the inlet of the Modul1000 to avoid dirt from getting into the vacuum system.



Caution

The electronic system of the Modul1000 may be damaged by the wrong supply voltage.

Check, if the local power supply voltage complies with the required supply voltage of the device.



Caution

The electronic system of the Modul1000 may be damaged by too high voltages.

The digital inputs are designed for maximum 30 V.



Caution

The electronic system of the Modul1000 may be damaged by too high electric loads.

The relay outputs should be connected to maximum 60V DC or 25 V AC / 1A at ohmic load. The semiconductor outputs should only be connected to 30V / 1A.



Caution

The electronic system of the Modul1000 can be destroyed when devices are connected to the Modul1000 whose electronic circuitry is not safely separated from the mains.

Only connect devices to the Modul1000 whose connections are safely separated from the power system.



Caution

The turbo-molecular pump may be damaged by jerky movements.
During operation, move the Modul1000 only carefully and smoothly.



Caution

Risk of damage.
The Modul1000 may be damaged by excess heat.
Pay attention to the serve messages and replace the dirty air filters.



Caution

Risk of damage.
The Modul1000 can overheat and fail when the openings are plugged.
Provide for free openings for air inlet and outlet.



Caution

The Modul1000 can be damaged when liquid gets into it.
If liquid has entered the Modul1000, do not switch it on and contact the INFICON-Service.



Caution

The Modul1000 may be damaged by being stored in unfavourable conditions (too damp, too hot, too cold, too high above sea level) for months or years. (refer to Technical Data!)

If the Modul1000 has been stored under such conditions, leave it switched off and contact the INFICON Service Department.



Caution

Risk of damage.
The Modul1000 may be damaged by improper transport conditions.
Always transport the Modul1000 in its original packaging.

3 Description of equipment

The Modul1000 is a helium leak detector which has been designed to be installed in leak test work stations or integrated machines.

The analysis system with turbo-molecularpump and a complete control unit are integrated in a compact housing. Depending on the set operating mode, the Modul1000 can execute overriding control functions in a leak test system.

Multiple signal and status outputs allow the universal integration in existing or new system versions.

The operating parameters set by the user are stored in a separate memory module (I•STICK) which can be withdrawn easily.

All device configurations and the necessary maintenance works can be performed without opening the device.

To generate the fore-vacuum required for the operation of the turbo-molecular pump, as well as for evacuation of the connected test sample, a fore-vacuum pump with a pumping speed of >2 m³/h has to be connected. It must be able to generate a final pressure of <1x10⁻² mbar.

Operating Manual

3.1 The housing



Fig. 3-1 Left side view and front view.

| Item | Description | Item | Description |
|------|----------------------------------|------|--|
| 1 | Inlet flange DN25 KF | 6 | air filter |
| 2 | Loudspeaker / Air inlet | | Mains fuses |
| 3 | Openings for unlocking the cover | 7 | Connection DN25 KF for Backing Pump |
| 4 | Recess handles | 8 | Vent connection FESTO coupling Hose 8 mm |
| 5 | Status LED | | |

(1011)

jinb80e1-h



Fig. 3-2 Right side view and back view

| Item | Description | Item | Description |
|------|----------------------------------|------|---|
| 3 | Openings for unlocking the cover | 9 | Mains socket with main switch and Mains fuses |
| 4 | Recess handles | 10 | Connection DN25 KF for Fore-vacuum pump or sniffer line |
| 5 | Status LED | 11 | Electrical interfaces |
| 6 | air filter | | |



Fig. 3-3 Cut-out in the bottom side of Modul1000

| Item | Description |
|------|--|
| 1 | Connection for the fore-vacuum pump (screwed flange) |

3.2 Interfaces

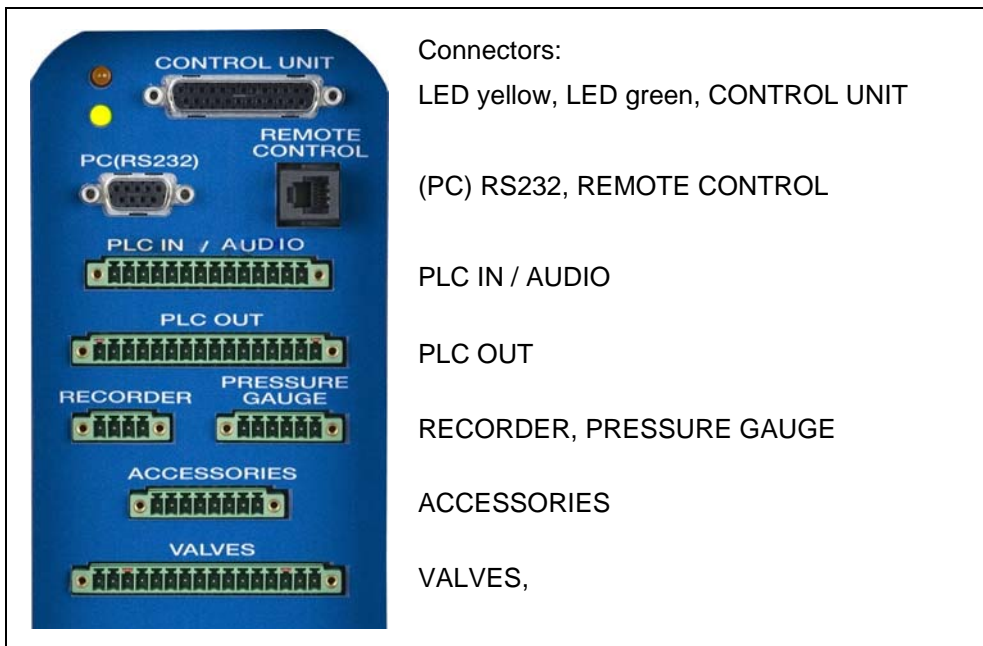

Fig. 3-4

The two 16-pin plug connectors PLC OUT and VALVES are keyed so they cannot be interchanged. For the PLC OUT, coding tongues are inserted on the pins 1 and 16, for the VALVES connector, the tongues are on the pins 3 and 14.

3.3 Operating options

The Modul1000 can be operated via the control unit for desktop operation or the control panel for the installation in a switch cabinet.

The Modul1000 provides an extensive software menu which serves for operation and configuration (refer to [6.11 Menu structure](#)). This control unit offers access to the menu structure.

The control unit can optionally be connected to the Modul1000 via 1 m or 5 m long connecting cables.

The control unit is for configuring and controlling the Modul1000 individually and parameters as well as measured values can be read out.

3.3.1 Desktop operation

The control unit can be placed on even desktops and does not slip.

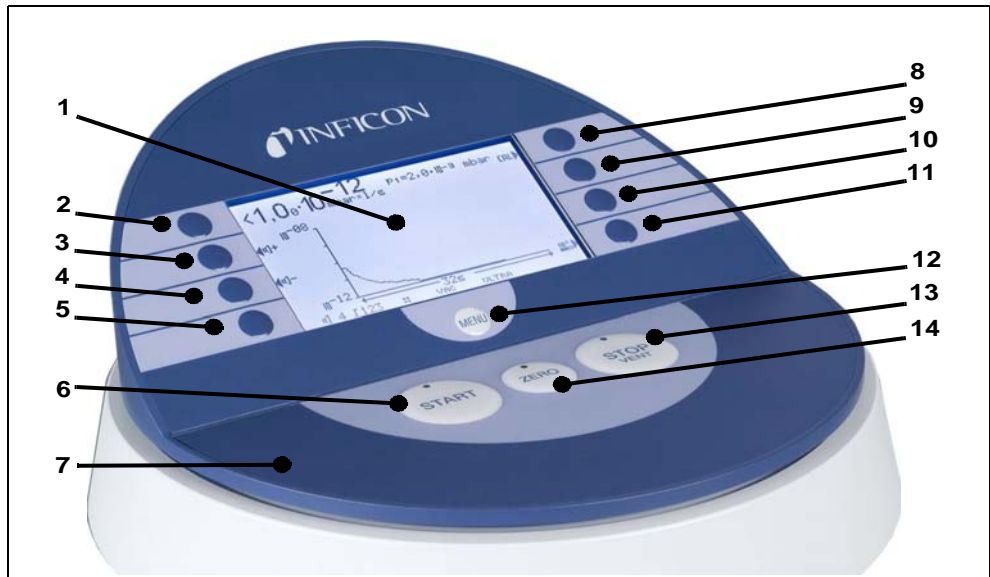

Fig. 3-5 Control Unit for Desktop Operation

| Item | Description | Item | Description |
|------|-----------------------|------|-----------------------------|
| 1 | LCD display | 8 | Soft Key no. 5 |
| 2 | Soft Key no. 1 | 9 | Soft Key no. 6 |
| 3 | Soft Key no. 2 | 10 | Soft Key no. 7 |
| 4 | Soft Key no. 3 | 11 | Soft Key no. 8 |
| 5 | Soft Key no. 4 | 12 | Menu button |
| 6 | START button with LED | 12 | STOP / Vent button with LED |
| 7 | Control Unit | 14 | ZERO button with LED |

3.3.2 Installation in switch cabinet

The control panel (Control unit as mounting version) is intended to be integrated in the front of a 19" rack system.



Fig. 3-6 Control panel for the installation in a switch cabinet

3.3.3 Remote control RC1000

The wireless remote control RC1000 allows the operation of the Modul1000 from a distance of maximum 100 m. The remote control can serve for controlling the functions START, STOP/VENT (STOP/Vent), ZERO (Background). It shows the measured leak rate on the display as bar graph, as digits, or as diagram (refer to Technical Manual of RC1000).

The measured values can be stored in the internal memory of the RC1000 for a recorded period of maximum 24 hours. Then the data can easily be transferred to a USB stick.

An internal trigger can be set to provide a warning if the limit leak rates are exceeded. An optical warning is shown on the display and an acoustic warning signal is sounded on the integrated loudspeaker or the connected headphones.

The RC1000 remote control is housed in a robust housing to enable ergonomic working. Magnets on the underside of the unit enable it to be attached to horizontal or vertical metal surfaces.

With the remote control RC1000, the leak test device Modul1000 can also be controlled via a 28 m long cable.



Fig. 3-7 RC1000 wireless remote control

3.4 Scope of delivery

- Leak test device for helium and hydrogen, Modul1000
- Power cords EU, US
- Set of spare fuses
- Folder with documents
- Tools for opening the cover 8 mm Allen-key
- Metering orifice DN25, 2 mm

3.5 Accessories

| Accessories | Cat. No. / Ref. No. |
|---|----------------------------|
| Sniffer line SL200 | 140 05 |
| Test chamber TC1000 | 551-005 |
| Set of male connectors for Interfaces | 551-110 |
| Control unit (desktop version) | 551-100 |
| Control unit (mounting version 19 inches) | 551-101 |
| Connecting cable for control unit, 1 m | 551-103 |
| Connecting cable for control unit, 5 m | 551-102 |
| | |
| Remote control | 20099022 |
| - Cable for remote control (required) | 20099027 |
| - Extension cable | 14090 |
| | |
| RC1000 remote control | |
| - RC1000WL wireless | 551-015 |
| - RC1000WL - cable version | 551-010 |
| - Extension cable, 8 m, for RC1000C | 14022 |

3.5.1 Sniffer line SL200

The Modul1000, in the version as vacuum or sniffer leak detector needs the sniffer line SL200 to be able to work in sniffer mode.

3.5.2 Test chamber TC1000

The vacuum chamber TC1000 serves for integrated testing of helium-filled parts. The test procedure can be configured individually in the software menu of Modul1000 and runs automatically after the chamber has been closed.

3.5.3 Set of male connectors for Interfaces

The connector kit includes the following plugs:

PLC IN / AUDIO,

PLC OUT,

RECORDER,

PRESSURE GAUGE,

VALVES,

ACCESSORIES

4 Installation



Warning

Back injury through heavy loads.

Two people should carry the Modul1000 or use a lifting device.

4.1 Mechanical Installation

The Modul1000 can be mounted on and below desktop workplaces. The leak test device may only be operated on horizontal surfaces. During the installation, make sure that the Modul1000 gets enough fresh air, especially the air inlet and outlet openings on the front and the back side have to be free. The maximum permissible ambient temperature of the Modul1000 may not be exceeded during operation!

4.2 Electrical installation

4.2.1 Mains socket

The device is connected to the power system via the delivered power cable. Please find the respective socket on the back of the device. (refer to [Fig. 3-2/9](#)).



Caution

Place the device in a way that you can always reach the power plug.

4.2.2 Electrical interfaces

All electrical interfaces of the Modul1000 are clearly visible arranged in a connecting area on the right side of the device (refer to Fig. 3-2).

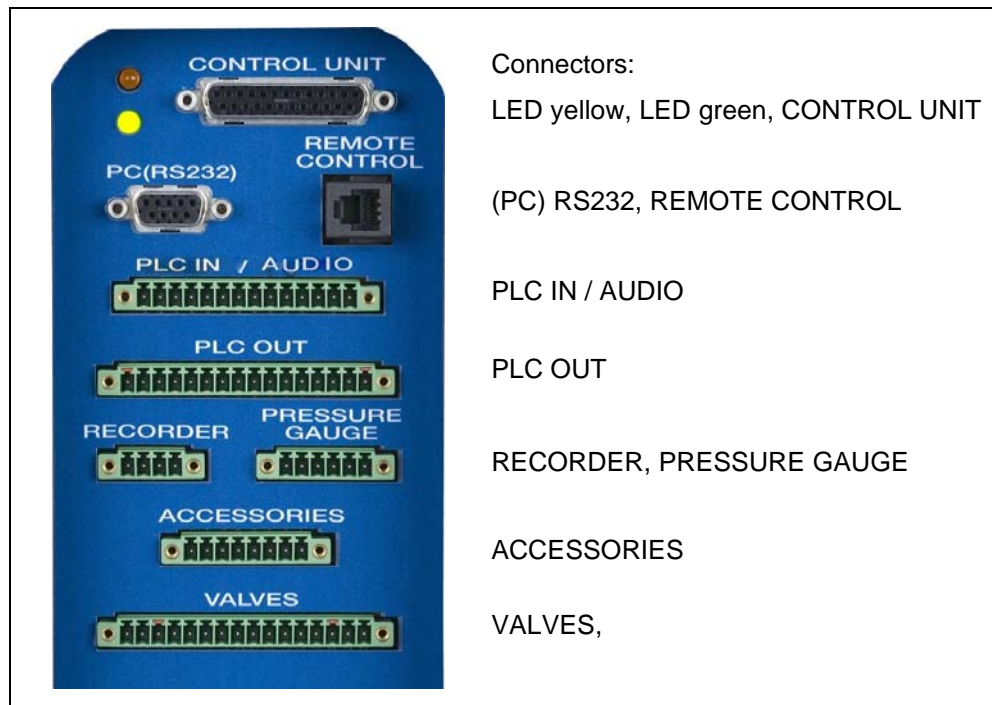

Fig. 4-1 Electrical interfaces

Valves

The connection VALVES is for controlling external valves.

PLC Inputs and outputs

To connect the control inputs and outputs (PLC IN /PLC OUT) use the connector kit. The connectors are not included in the scope of delivery, but are available as accessories (see 3.5, Set of male connectors for Interfaces, Part-No. 551-110)

Graphical control unit

A graphical control unit is connected to CONTROL UNIT via an appropriate connecting cable.

Hand set

The remote control is connected to REMOTE CONTROL.

Sniffer line SL200 or test chamber
TC1000 (ACCESSORIES)

The connection ACCESSORIES serves for connecting the sniffer line SL200 or the test chamber TC1000.

External Pressure gauge

If the Modul1000 is used in Commander mode, an additional pressure gauge has to be connected to PRESSURE GAUGE. Connect the pressure gauge as follows with the 8-pin Phoenix-plug "PRESSURE GAUGE".

| Pin | Assignment |
|-----|--|
| 1 | 24V fuse-protected with F3 on the interface board (0.8A, maximum output current, on this pin together with the pin 1 on connection PLC IN) |
| 2 | GND |
| 3 | Input 1 |
| 4 | GND to input 1 |
| 5 | Input 2 (is not supported by the current software) |
| 6 | GND to input 2 |

Notice: The pressure transmitters to be connected can be supplied via the contacts 1 and 2 of the Modul1000.
If they are supplied by external power supply units, ensure that the contacts 4 and 6 may only have a maximal potential of $\pm 4V$ compared to contact 2. Otherwise it could be damaged.

Notice: The sensor is adjusted correctly, when the zero point and the full-scale deflection comply with the output characteristic.

Danger

Danger of fatal injuries due to electric shock!

First, disconnect the leak test device from the power supply network and then remove the housing.

The Modul1000 can process measured current or voltage values. When delivered, the Input 1 is configured for current measurement 4... 20 mA, Input 2 for voltage measurement 0... 10 V.

To change the configuration of the input of the pressure gauge, the respective jumper on the interface card in Modul1000 has to be placed onto another position. To do that, open the device.

The jumpers are located on the interface board and are accessible after opening the cover.

By changing the position of the jumper on the connector XP5, the setting of the Input 1 can be changed. For a current signal, Pin 1 and Pin 2 of XP5 are connected, for a voltage signal, connect Pin 2 and 3.

By changing the jumper position on the connector XP4, the setting of the Input 2 will be changed. However, this input is not supported in the current software.

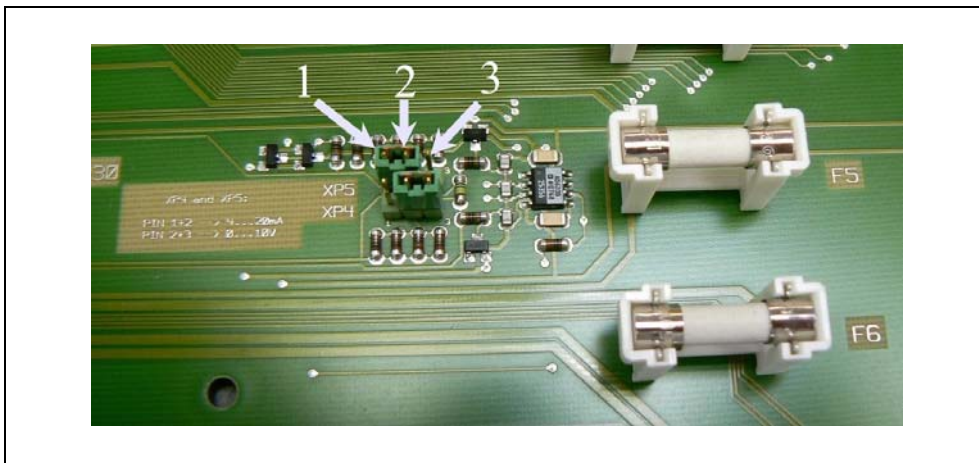

Fig. 4-2 Jumper XP5 and XP4

| Item | Description | Item | Description |
|------|-------------|------|-------------|
| 1 | Pin 1 | 3 | Pin 3 |
| 2 | Pin 2 | | |

Recorder Output (analogue)

The two Recorder outputs (analogue outputs) may be used to log the leak rate, the inlet pressure or the fore-vacuum pressure. The output voltage is updated every 50 ms.

| Pin | Assignment |
|-----|-------------------------------------|
| 1 | Recorder Output 1 (analogue output) |
| 2 | GND |
| 3 | GND |
| 4 | Recorder Output 2 (analogue output) |

RS232 Interface

The RS232 interface serves for connecting a PC directly to the Modul1000.

The Modul1000 is then directly controlled by the respective instruction sets as described in the interface description.

| Pin | Assignment |
|-----|---|
| 1 | 24V can tied-in via the jumper XT2, maximum current consumption 0.3 A (Pin 2 and 3 connected). As delivered, 24 V are not tied-in, Pin 1 and 2 connected. |
| 2 | TxD |
| 3 | RxD |
| 4 | GND 24 V can be tied-in via jumper XT1 (Pin 2 and 3 connected). On delivery, GND 24 V is not tied-in (Pin 1 and 2 connected). |
| 5 | GND RS232 |
| 6 | not used |
| 7 | not used |
| 8 | not used |
| 9 | not used |

Using the jumpers XT1 or XT2, Earth or 24 V can be connected to the RS232 interface by changing the positions of the jumper (Pin 2 and 3). On delivery: XT1 or XT2, Pin 1 and 2 bridged ≅ "default setting (Standard) RS232".

STOP
Danger

Danger of fatal injuries due to electric shock!

First, disconnect the leak test device from the power supply network and then remove the housing.

The jumpers are located on the interface board and are accessible after opening the cover.

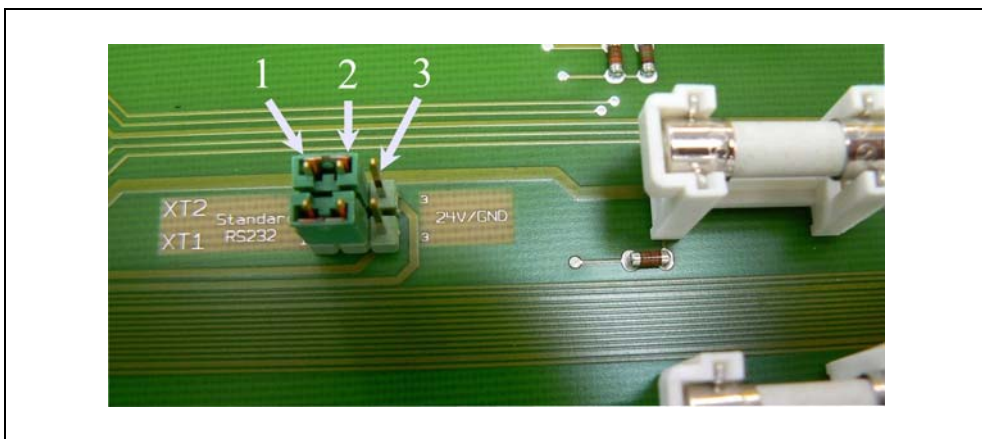

Fig. 4-3 Jumper XT2 and XT1

| Item | Description |
|------|-------------|
| 1 | Pin 1 |
| 2 | Pin 2 |
| 3 | Pin 3 |

4.2.3 Vacuum connections

Fore-vacuum pump

The connection for the required fore-vacuum pump is on the left front side or on the bottom of the device. Alternatively, the pump connection of the vacuum version of the Modul1000 can also be on the right side.

- 1 Unscrew the connecting flange using the jaw-wrench SW13, to modify it and remove the sealing.
- 2 Unscrew the locking plug of the connection you want to use
Make sure you save the sealing.
- 3 Screw the locking plug with the sealing into the opening of the removed connection flange.
- 4 Screw in the connecting flange with the sealing.

Notice: For the sniffer version of the Modul1000, only the pump connections on the left side or on the bottom side can be used.

The used fore-vacuum pump must meet the following specifications:

- The connecting hose should have a minimal diameter of 15 mm.
- The fore-vacuum pump should provide a pumping speed of $>2 \text{ m}^3/\text{h}$
- and a possible ultimate pressure of $<1 \times 10^{-2} \text{ mbar}$.

If the fore-vacuum pump is equipped with a solenoid gas ballast valve or purge gas valve, it can be controlled via the valve output V22 of the Modul1000.

Test sample/Test Equipment

The test sample or the test equipment are connected using the DN25 KF inlet flange on the top of the Modul1000.

To be able to measure with the leak test device also in case of pressures higher than 0.4 mbar, the metering orifice, which is in the scope of delivery, can be mounted before the inlet of the leak test device. If the metering orifice is installed in the suction line of the leak test device, the maximum inlet pressure will be 3 mbar.

Because the pumping speed is greatly reduced when a metering orifice is inserted, it will be reasonable to use a partial flow pump for evacuation.

To achieve short signal response times of the Modul1000, the orifice should be mounted as close as possible to test sample, test equipment.

In Modul1000b, the metering orifice has already been installed and can also measure until 3 mbar.

Notice: The maximum permissible load vertically on the flange is 400 N.

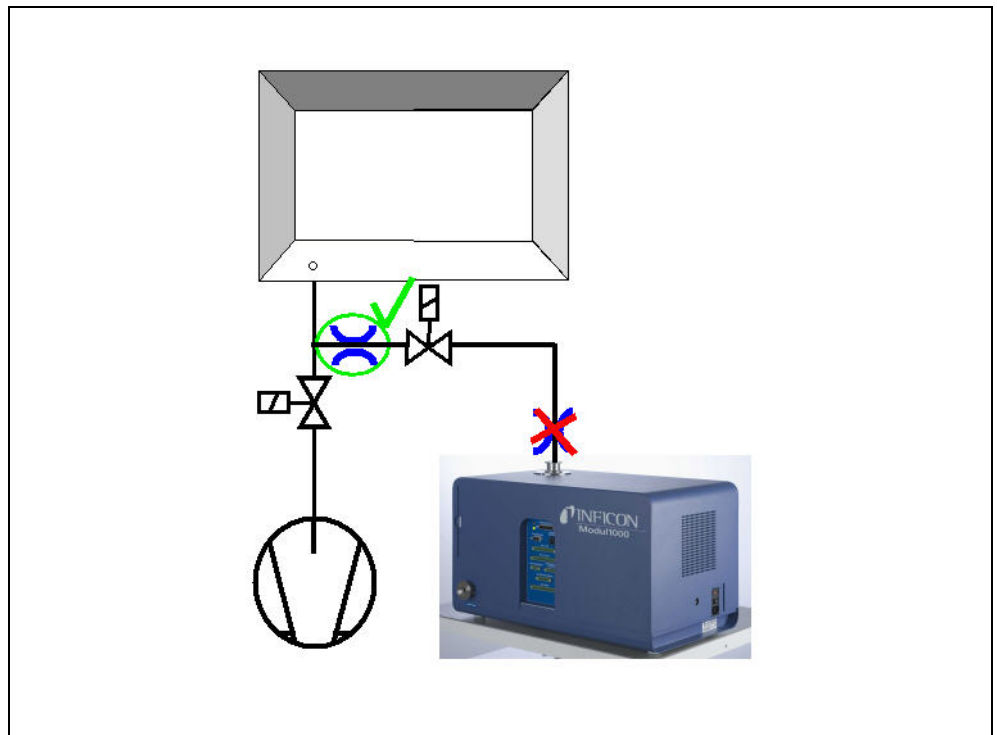

Fig. 4-4 Installation of metering orifice

Ventilation

Usually the parts under test are vented with ambient air after the test has been finished. If it is required, the parts can be vented with a different gas type (i. e. fresh air, dry air, nitrogen, ...) at a pressure of max. 1050 mbar. In these cases, the gas supply has to be connected to flood connection (8 mm hose connection) on the left side of the device. The gas pressure on the flood connection may not exceed 1100 mbar (absolute).

It is also possible to connect an additional external ventilating valve to the valve output V21.

Sniffer line

The connection for the sniffer line exists only for the sniffer version of the Modul1000 (catalogue number 550-310). This connection is for the optional sniffer line SL200. The SL200 is connected to the power system via the connector socket ACCESSORIES.

5 Working Modes

There are the following vacuum modes:

- Vacuum,
- Commander,
- Auto Leak Test.

In this operating mode, it is possible to use a partial flow pump.

The sniffer version of the Modul1000 also provides the operating mode:

- Sniff.

5.1 Vacuum

In standard Vacuum mode, the Modul1000 is operated as „Stand Alone“ leak detector.

The unit under test or the vacuum chamber are only evacuated via the inlet flange of the leak detector. The pumping speed on the inlet of the leak detector depends on the used fore-vacuum pump and on the conductivity ratios of the device.

If the pressure is lower than 0.4 mbar, the device will switch over to the Measuring mode and display the measured leak rate.

When measuring, the pumping speed at the inlet is 2.5 l/s.

The effective pumping speed at your chamber is dependent on the integration of the Modul1000.

5.2 Partial Flow Mode

To increase the effective pumping speed on the vacuum chamber or the test sample, an external partial flow valve can be connected to the valve output V20. The increased pumping speed accelerates the evacuation processes and the signal response time of the Modul1000.

Depending on the settings, the partial flow pump can optionally be added via an external partial flow valve only for evacuation or for evacuation during the measurement.

If the partial flow pump is also added during the measurement, the pumping speed of the partial flow pump for helium has to be considered. In this case, adjust the machine factor as required (refer to chapter 6.9). Furthermore, an external calibration is recommended (refer to chapter 6.6).

For fast venting of the device, the connection of an additional external vent valve V21 will be possible.

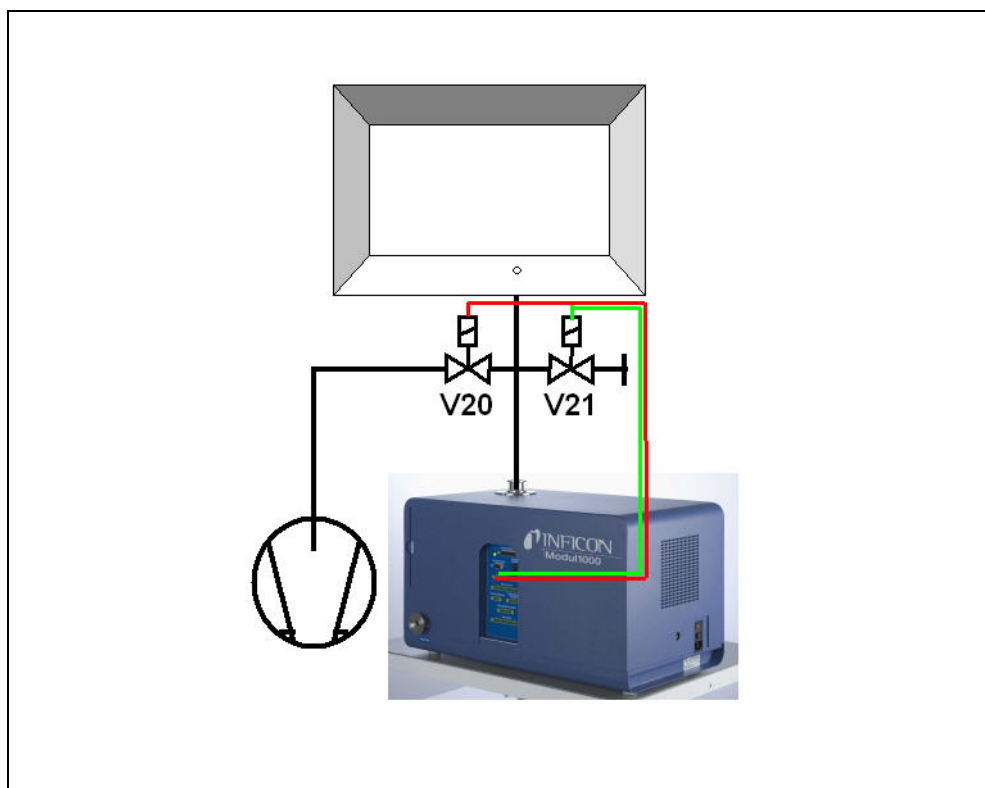

Fig. 5-1 Partial flow mode

| | | | |
|------|--------------------|------|-------------------|
| Item | Description | Item | Description |
| V20 | Partial flow valve | V21 | Ventilating valve |

5.3 Auto Leak Test

In Auto Leak Test mode, parts prefilled with helium can be tested integrated in a vacuum chamber. In this case, the Modul1000 does all control functions completely for the test run.

The test run is divided into the following steps:

Evacuation of the vacuum chamber,

Measurement of leak rate and

then venting of the vacuum chamber.

At the end of the test, the device displays „PASS“ on the control panel provided that the leak rate did not exceed the set trigger value during the measuring time. If the trigger value is exceeded, the device will display the message „FAIL“.

Optionally, the test can also be carried out in Partial Flow mode.

After pressing the START button, the whole test runs automatically. When using the optional test chamber TC1000, the test cycle starts automatically as soon as the chamber cover is closed.

5.3.1 Auto Leak Test Settings

Select the Auto Leak Test mode via the control panel or the RS232 interface.

The test run can be adapted to your special application of the leak detector. The corresponding settings can be entered via the control panel or the RS232 interface (refer to Interface Description).

Measuring time

The measuring time starts as soon as the Modul1000 switches over from the evacuation phase to the Measuring mode. The possible time settings range from 1 second to 30 minutes.

At the end of the measuring time, the measured value is displayed.

Trigger level

If the set trigger level 1 is exceeded at the end of the measurement cycle, the Modul1000 indicates the message „FAIL“ and hence, it signals a leaky test sample.

Part number

In the software menu, the parts counter can be enabled, which assigns a number to the individual measurement cycles. On the menu screen "Test report", the last 12 measured results can be displayed with date and test result.

Series error message

The menu provides a setting, with which a series error message can be displayed when a certain number of consecutive errors with the "FAIL" result occur. The set number of consecutive measurements after which the Modul1000 displays a series error message can vary between 2 and 9. If not required, it can be disabled.

To ensure that such an abundance of consecutive „FAIL“- messages is not caused by the helium background of the test equipment, a reference measurement is recommended.

Reference measurement

If the ambient helium emitted by the chamber is significant in relation to the target leak rate, it is possible to perform a reference measurement.

In the software menu, it is possible to enable a reference measurement. If it is enabled, it can be called via the Measurement screen.

During the reference measurement, the Modul1000 determines the internal helium background of the test equipment and then it deducts this values from the values of following measuring cycles.

The reduce the background of the test equipment in case of a reference measurement, the vacuum system of the device is evacuated and vented for three times.

5.4 Commander mode

If the Modul1000 is integrated in a leak detector system, in Commander mode, it can control the whole test in the integrated chamber. All necessary valves for filling the test sample with helium as well as the necessary pressure gauge can directly be connected to the Modul1000. The test run can only include a device for helium recovery.

Optionally, the test can also be carried out in Partial Flow mode to accelerate the leak detection.

5.4.1 Design of a leak detector system

Design of a leak detector system with Modul1000- -Commander function is mainly the same as that of the conventional integrated leak test system.

The vacuum chamber is evacuated by the Modul1000, optionally also in partial flow mode (Fig. 5-1 Partial flow mode). The test sample in the vacuum chamber is connected to the helium filling station through the chamber walls and is filled with helium after the chamber has been evacuated.

Due to the difference between the helium pressure in the test sample and the vacuum in the vacuum chamber, the helium of a leaky part flows out of the leak into the vacuum chamber and into the leak test device where it can be measured as gas leak.

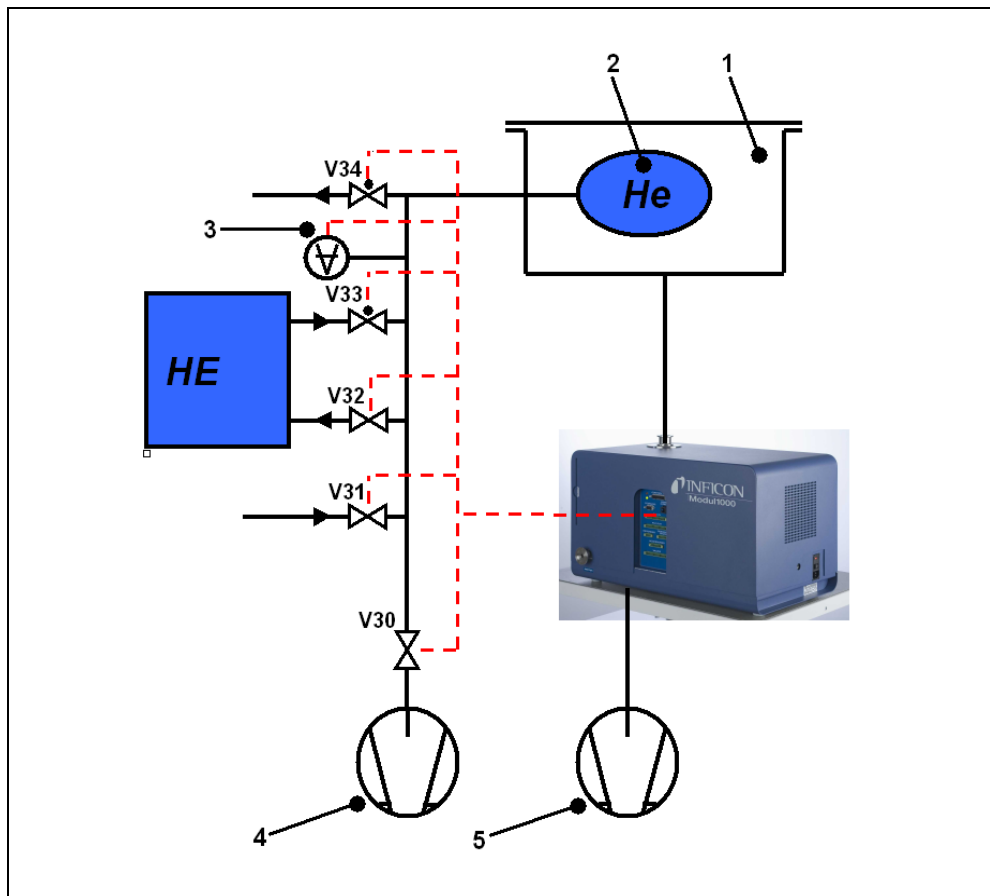

Fig. 5-2 Leak detector system

| Item | Description | Item | Description |
|------|-------------------------------------|------|----------------------------|
| V30 | Valve evacuation (test sample) | 1 | Vacuum chamber |
| V31 | Flood valve (test sample) | 2 | Test sample |
| V32 | Valve for helium recovery | 3 | Pressure gauge |
| V33 | Filling valve (test sample) | 4 | Vacuum valve (test sample) |
| V34 | Emergency valve (de-energized open) | 5 | Fore-pump (Modul1000) |

Helium filling station

The helium filling station consists of a vacuum pump, the valves V30- V34, a pressure gauge and the helium supply unit.

Valves V30, V31, V32, V33, V34

The test run of the Commander software includes the control of all valves necessary for the helium filling procedure of the test sample. The valves are controlled via the „VALVES“ connection.

Notice: We recommend using pressure activated valves.

Pressure gauge

The test sample is filled with helium and the gross leak test are pressure controlled and therefore, they need a pressure gauge which has a measuring range of < 50 mbar reaching to the maximum filling pressure of the test sample. The characteristics and the measuring range of the used measuring point can be set on the Modul1000. The pressure gauge is connected to the „PRESSURE GAUGE“ terminal on the right side of the device.

Vacuum pump

The vacuum pump evacuates the test sample before it is filled with helium to remove the air from the part as well as possible. We recommend using a pump with a final pressure of < 50 mbar.

5.4.2 Test sequence of events

- 1** The test sample is in the vacuum chamber which is connected to the inlet of Modul1000. The unit under test is in the vacuum chamber which is connected to the inlet of Modul1000.
- 2** After the START signal, the Modul1000 starts evacuating the vacuum chamber. If a partial flow pump is connected with Modul1000, the partial flow valve V20 (Fig. 5-1) will be actuated and the test run is accordingly supported by the partial flow pump.
- 3** Before the actual helium test is executed, a gross leak test is carried out, to detect gross leaks in the test sample or in the leak detector. When a chamber pressure of 100 mbar is reached, it will be checked, whether the pressure of the test sample has dropped and is lower than the set pressure p_A_ for the gross leak test. If this is the case, the measuring cycle will be interrupted indicating the error message 91.
- 4** If the system passes the gross leak test, valve V30 will be opened and the test sample will be evacuated. If the system passes the gross leak test, the valve V30 will open and the test sample will be evacuated. Otherwise, the measuring cycle will be interrupted indicating the error message 92.
- 5** If the chamber pressure drops within the set time t_F_Readiness_for_measurement down to the change-over pressure, the device will switch over to Measuring mode. This change-over pressure can be set in the following menu:
Main menu --> Settings --> Monitoring --> Pressure limits for vacuum areas"
between 0.2 mbar and 0.4 mbar.
Depending on the settings in "Background suppression", an automatic background subtraction will be carried out, if necessary:

- When "OFF" is set: no zeroing is carried out
- When "ON" is set: zeroing is carried out after the $t_{B_zeroing}$ delay time
- When "STABLE" is set: zeroing will be carried out within the t_{B_zero} delay time provided that the leak rate signal is stable enough to indicate a leak of the set trigger level 1. If this condition is not complied with within the t_{B_zero} delay time, the measuring cycle will be stopped and error message 98 will be generated.

If the chamber pressure is not low enough within the set time $t_{F_Readiness_for_measurement}$ to switch over to the measuring mode, the test procedure will be interrupted indicating the error message 94.

- 6 After the evacuation of the test sample, the valve V33 is opened and the filling process of the part with helium can start. If the pressure in the test sample reaches the set filling pressure $p_{C_Filling_pressure}$ within the set time $t_{C_Filling_time}$, the valve V33 will be closed again and the filling process will be completed. If the filling pressure is not reached on time, the measuring cycle will be interrupted indicating the error message 93.
- 7 The actual leak test is now started. The measured leak rate is displayed when the set time $t_{G_Measuring_time}$ has expired. If the pressure of the test sample drops below the pressure $p_{E_Pressure_drop_threshold}$ during the leak test due to a leak in the system, the measuring cycle will be interrupted indicating the error message 99.
- 8 At the end of the measuring time, the valve V32 is opened. Helium is returned from the test sample to the helium filling facility until the pressure in the sample has reached the depressurizing pressure $p_{D_Depressurizing_pressure}$. After that, V32 is closed again.
If this does not happen within the set time $t_{D_Depressurizing_time}$, the measuring cycle will be interrupted indicating the error message 95.
- 9 To remove the residual helium from the test sample, valve V30 opens and the test sample is evacuated by the pump 4 until the pressure $p_{B_Evacuation_pressure}$ is reached.
This has to be done within the set time $t_{A_Evacuating_time}$, otherwise the measuring cycle will be interrupted indicating the error message 96.
- 10 Valve V30 will be closed. The unit under test is vented to reach atmospheric pressure via valve V31.
If the set filling pressure for the test sample $p_{A_Gross_leak_test}$ is not reached within the time $t_{E_Ventilation_time}$, the measuring cycle will be interrupted indicating the error message 97.
- 11 After that, the vacuum chamber is ventilated by the Modul1000 (and the external flood valve V21 (Fig. 5-1), if connected) to reach the atmospheric pressure.

5.5 Sniff mode tips

The Modul1000 Sniffer version can be used as vacuum leak detector or as sniffer leak detector.

To use it as sniffer leak detector, the optimized sniffer line SL200 has to be connected to „Sniff“ on the right side of the Modul1000. In Measuring mode, the module draws a constant gas flow through the sniffer line. The helium in the gas flow is indicated as leak rate.

In Sniff mode, the detection limit is restricted to 1×10^{-7} mbarl/s due to the high atmospheric helium background.

The gas flow rate through the sniffer line is approximately 25 sccm.

It is electrically connected by the "ACCESSORIES" connector.

The operating mode must be set to "Sniff mode".

In "SNIFF"-mode, the red LED on the sniffer handle indicates a bad test sample and the green LED indicates a good test sample.

The active push-button on the sniffer handle of the sniffer line can be used for switching on the external background suppression. If the push-button is pressed for a longer time (3 seconds), the external background suppression is switched off again.

6 Operation

6.1 Switching ON

Install the device as described in the Installation chapter. Connect the power cable. Switch the device ON. The mains switch and the connection for the power cable are at the back of the device.

After the mains switch has been actuated the device runs up automatically.

In run-up mode (≤ 3 Min.) the following items appear on the display:

- Speed of the turbo-molecular pump
- Fore-vacuum pressure
- State of emission
- Active filament
- A bar graph which shows the run-up progress

After the run-up has been completed, the Modul1000 is in „Standby“ mode.

6.2 Status LED

The LEDs show the operating mode of the device:

| Operating mode: | LED, green | LED, yellow |
|---|-----------------------|-----------------------|
| Run-up | Flashes | Flashes |
| Standby/Vent | On | Off |
| Evacuate | On | Flashes slowly |
| Measuring | On | On |
| Calibrating | Flashes synchronously | Flashes synchronously |
| Error / Warnings / Maintenance messages | Off | Flashes fast |

6.3 Control

The Modul1000 can be controlled via the control unit, the remote control, the PLC inputs or via the RS232-interface. These options can be selected in the menu item „Control location“.

(refer to: Main menu → Settings → Interfaces → Control location)

Control Panel

The optional control unit can be used for programming and controlling of all device functions and information can be read out.

The functions and the menu structures of the control unit for desktop operation (refer to chapt. 3.3.1) and the control panel for the rack installation (refer to chapt. 3.3.2) are the same.

Hand set

The optional remote control (refer to chapt. 3.3.3) includes the main functions Start, Stop, Vent, and Zero. Additionally the volume can be controlled.

If „LOCK“ is displayed, the control of the Modul1000 via the remote control was disabled in the menu item „Control location“.

RS232 Interface

The RS232 interface serves for connecting a PC directly to the Modul1000.

Then, the control commands will be sent by appropriate interface commands to the device, as described in the interface description.

PLC Inputs and outputs

The most important control commands can also be sent to the Modul1000 via a PLC. The functions of the inputs and outputs can be configured.

6.4 Control commands

The following control commands can optionally be sent to the Modul1000 to the control unit / remote control via the PLC control inputs or via the RS232 interface.

START

If the control unit is connected, the LED in the START-button will flash during the evacuation process.

During the measurement, it will light up continuously.

If the START button on the control unit is pressed during the measurement, the maximum leak rate display will be enabled (Hold function). This is the highest leak rate which has been measured since the start.

If the START button is repeatedly pressed, this Hold function will be initialized.

The LED in the button indicates the status:

| | |
|--------------|----------------------|
| LED flashes: | Evacuate |
| LED ON: | Measuring operation: |

By pressing the START button, the Modul1000 starts to evacuate the connected test sample.

If the pressure on the inlet of the leak test device reaches < 0.4 mbar, the Modul1000 will automatically switch over to the Measuring mode.

This pressure limit can be set in the following menu:

Settings → Monitoring → Pressure limit for the vacuum area

.

STOP / VENT

The STOP command stops the measurement and the leak test device switches over to the Standby mode.

If you press the STOP button briefly, the measurements are interrupted.

If the button is pressed longer, the inlet is vented according to the conditions defined in the menu "Vent delay".

LED ON: Inlet vented

ZERO

Pressing the ZERO button activates the background suppression. To disable the background suppression again, it will be enough to keep the ZERO push button pressed for about 3 seconds.

The status of the ZERO-button is indicated by the LED:

LED ON: ZERO enabled

Notice: The ZERO function should be started only when the background signal is stable. In the I-ZERO setting, the ZERO function can be used only then when the dropping background signal becomes constant.

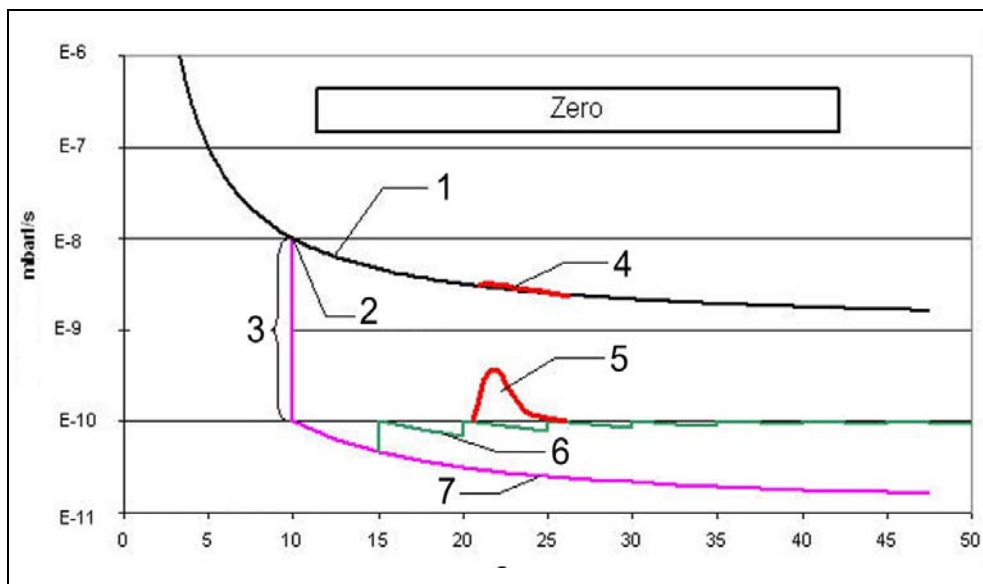

Fig. 6-3 Zero function (background suppression)

| Item | Description | Item | Description |
|------|---------------------------------|------|------------------------------|
| 1 | Leak rate signal without ZERO | 5 | Leak 5E-10 mbarl/s with ZERO |
| 2 | ZERO is enabled | 6 | Floating Zero adjustment |
| 3 | Suppression of two decades | 7 | No Zero-adjustment |
| 4 | Leak 5E-10 mbarl/s without ZERO | | |

Menu

Pressing the MENU button displays the selection menu.

Display-buttons

The functions of the eight buttons on the left or on the right of the display depend on the selected menu. Please find the description of relating functions on the display.

Numerical Entries

If you have opened a menu screen for numerical entries please proceed as follows:

- If you do not want to change any digits, press key „Cancel“ to abort.
- The digit that can be changed is displayed shaded. Use the keys No. 8 and No. 4 and go to the position to be changed.
- To change a digit to a specific number press the corresponding pair of numbers. A sub-menu opens and the desired number can be selected. The sub-menu closes automatically and the next whole number will be displayed with inverted colours and can be changed. Having reached the last digit all corrections have to be confirmed by OK.

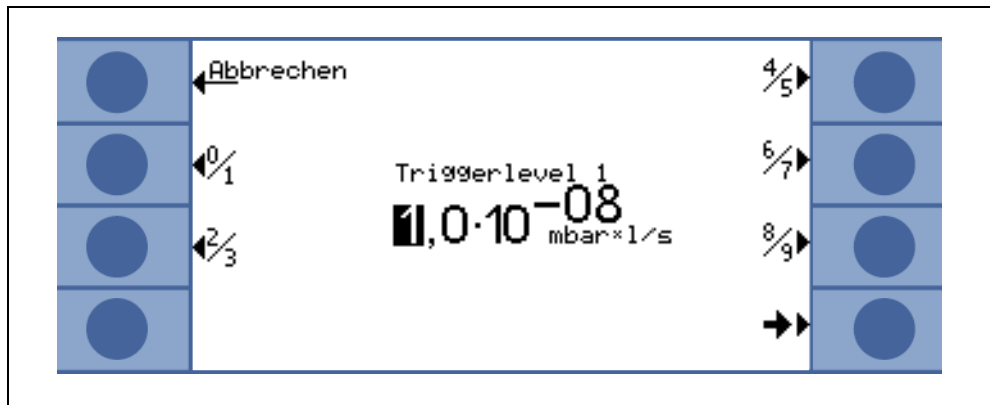

Fig. 6-4 Examples for a numeric input of Trigger Level 1

To change the trigger level from 1.0×10^{-9} mbar/l/s to 3×10^{-9} mbar/l/s please press 2/3 (button No. 3). A sub-menu is opened, in which the desired value 3 (button 4) can be selected.

6.5 Display



The display shows measuring values, operating modes, device parameters and their values, as well as functions of the eight buttons on the left and on the right side of the display.

Run up

After it has been switched on, the Modul1000 displays some status information.

Status line

The following details on the device are shown in the status line at the bottom of the display after the Modul1000 has run up.

| Display symbols | Meaning | Explanation |
|--|-----------------------|---|
|  | Sound volume | Refer to chapter Volume for the audible signal |
| S1, 2, 3 | Trigger Level 1, 2, 3 | If the trigger values are exceeded these signs are inverted. (White on black background.) |
| •• | Detected mass | The number of dots stands for the mass number (4 dots = helium, 2 dots = hydrogen). |
|  | Warning triangle | Refer to chapter 4.4.2 |
| VAC | Operating Mode | VAC, SNIFF, COMMAND or AUTO LEAK TEST stand for the selected operating mode. |
| ZERO | ZERO | Indicates if ZERO-function is active. |
| COR | Corrected leak rate | It shows if the leak rate is corrected with the machines factor. |

Standby

After the run-up has been completed, the Modul1000 automatically switches over to Standby mode and is ready for measurement.

Evacuation

Pressing the START button causes the Modul1000 to evacuate the inlet. The evacuation time depends on the volume connected the Modul1000 and the fore-vacuum pump or the partial flow pump.

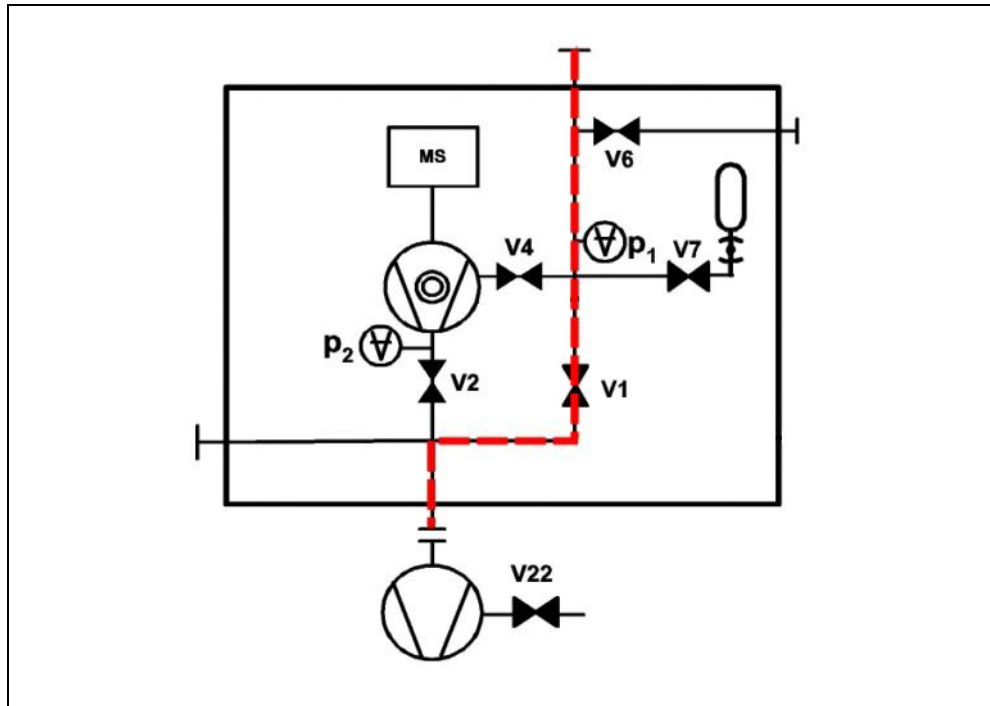

Fig. 6-5 Evacuate

Measuring

When the pressure on the inlet of the Modul1000 drops below the set lower pressure limit, the device will change over to measuring mode.

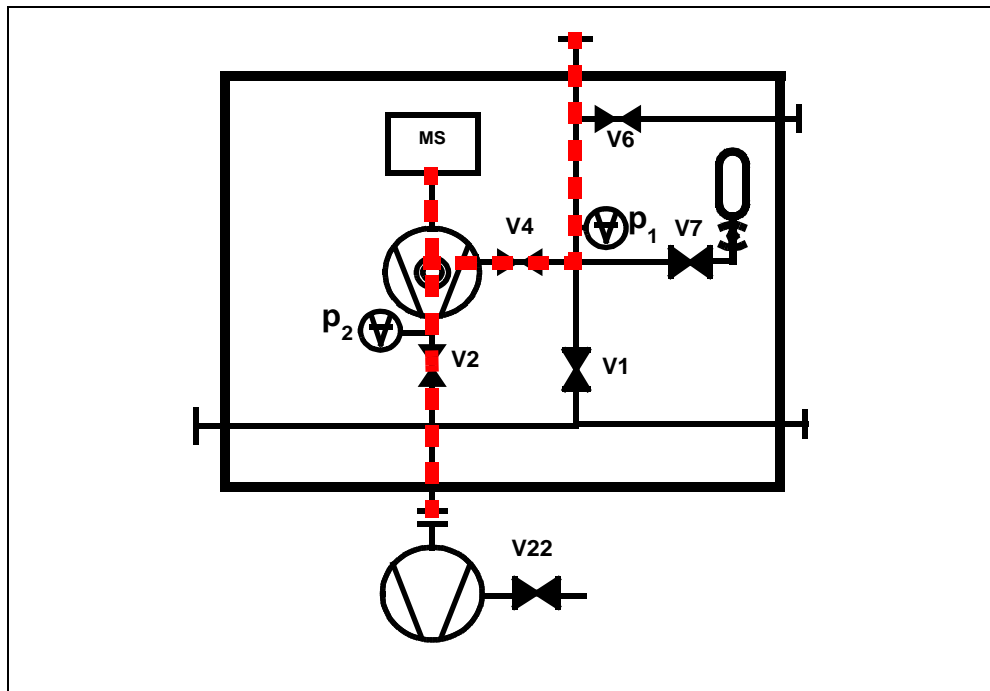

Fig. 6-6 Measuring

Display of measured values

In Measuring mode, two ways of displaying the measured values are available.

- Numeric display with big sized numbers as bar graph.

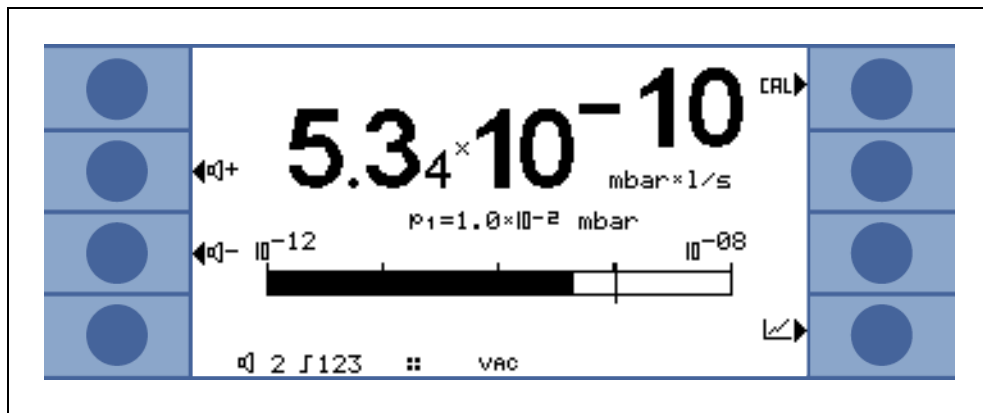

Fig. 6-7

- Graphic display as function of the measuring time

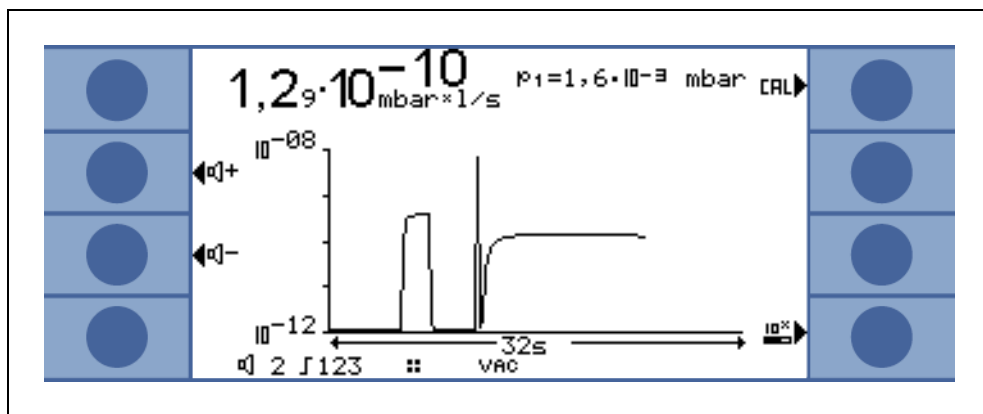

Fig. 6-8

You can switch over between the numeric display and the graphic display using the button No. 8. It is labelled with the symbols for numeric and graphic display.

6.6 Calibration in Vacuum mode

The Modul1000 can be calibrated in two different ways: For each calibration, calibrate the mass spectrometer to achieve maximum sensitivity (Autotune). Depending on the applied test leak, internal or external calibration is required.

No matter, which control location is used, the calibration can be started in the following ways:

| | Set control location |
|--------------------|---------------------------------------|
| Internal manual | LOCAL, RS232 ASCII |
| Internal automatic | LOCAL, RS232 ASCII, RS232 BINARY, PLC |
| External manual | LOCAL, RS232 ASCII, RS232 BINARY, PLC |
| External automatic | LOCAL, RS232 ASCII |

For the internal calibration, the test leak integrated in Modul1000 is used.

For the external calibration, a separate test leak is required. External calibrations have the advantage that they can be carried out under boundary conditions (pressure, measuring time) similar or equal to the later measurements.

If a control unit is connected to the Modul1000, the LEDs in the buttons START, STOP / VENT and ZERO light up during the calibration.

Notice: To get an optimized calibration the machine has to warm up for at least 20 minutes before use.

Internal Calibration

If a partial flow pump is used in measuring mode, set the correct machine factor before the 1st calibration.

The internal calibration is not done in partial flow mode, not even if it is set to „Partial flow in measuring mode“. It will be corrected via the set machine factor.

Automatic Internal Calibration

After starting the calibration, the whole calibration procedure runs automatically.

In this case, the signal transient time of the test leak (CAL-transient time) is used which can be set in the menu. Before, it must be adjusted to the volume at the inlet. The CAL-transient time increases depending on the volume enclosed at the inlet.

Manual Internal Calibration

After starting the Calibration, the Modul1000 opens the internal test leak and evacuates the inlet. The signal transient time stretches depending on the connected volume stretches.

Therefore the user has to confirm that the signal has become constant.

External Calibration

The external calibration has the advantage that it considers the application-specific measuring conditions. The external calibration leak can be connected to the vacuum chamber.

Calibration leaks with solenoid valves can be connected to the terminal VALVES at the back of the device. Then, the Modul1000 automatically controls the valve.

Before the calibration, enter the corresponding value of the calibration leak which shall be used for calibrating the Modul1000 in the settings of the Modul1000. This can be done via the optional control unit or the RS232 interface.

The external calibration in the Partial Flow mode is carried out with the setting „Fore and partial flow pump“ in the item „Measure mode“. (see chapt. 6.12.6.1)

Automatic External Calibration

The automatic external calibration requires a calibration leak with solenoid valve. It is electrically connected via the VALVES connector.

After starting the automatic external calibration, the Modul1000 runs through the complete calibration sequence.

In this case, the signal transient time of the test leak (CAL-transient time) is used which can be set in the menu. Before, it must be adjusted to the volume at the inlet.

The CAL-transient time increases depending on the volume enclosed at the inlet.

Manual external Calibration

In case of the manual external calibration, the test leak has to be opened and closed manually.

Also acknowledge the steady-state test leak signal manually.

The control unit or the control panel guides the user through the calibration routine via the display.

6.7 Calibration in Sniff mode

It only applies for devices with the catalogue No. 550-310 and 550-330.

In Sniff mode, calibration is done in the same way as it is done for the external manual calibration in Vacuum mode.

With the optional sniffer line connected to the Modul1000, it is required to measure a sniffer test leak and a helium background.

Acknowledge the steady-state test leak signal and the steady-state background value manually.

6.8 Calibration in Auto Leak Test

There are four different ways of calibration:

- Internal automatic
- Internal manual
- External automatic
- External manual

For the external calibration, a separate test leak is required, which is mounted on the chamber.

In Partial Flow mode, always perform an external calibration.

Sequence of calibration:

- 1** open the test leak or it opens automatically,
- 2** evacuate,
- 3** acknowledge steady-state signal when calibrate manually,
- 4** autotune (Calibration to maximum sensitivity),
- 5** vent to atmospheric pressure,
- 6** evacuate, after the measuring time is over, take the signal with open test leak,
- 7** vent to atmospheric pressure,:
- 8** close the test leak, evacuate, after the measuring time take the background signal,
- 9** vent to atmospheric pressure.

6.9 Calibration in Commander mode

During the calibration, the test gas supply is not enabled.

There are four different ways of calibration:

- Internal automatic
- Internal manual
- External automatic
- External manual

For the external calibration, a separate test leak is required, which is mounted on the chamber.

The calibration procedure is the same as it is for the vacuum mode.

6.10 Machine factor

The machine factor takes into account that the Modul1000 is used in parallel with a pumping system.(partial flow method).

Because in such a system configuration only a part of the leak gas flow reaches the leak test device and is detected, first. the Modul1000 displays measured values on the basis of the internal calibration which are smaller due to the partial flow ratio.

To avoid this, the machine factor can be saved in the software menu of the Modul1000. Then, after an internal calibration, the measured leak rates are displayed multiplied by the machine factor.

The machine factor can be estimated considering the Helium pumping speed of the Modul1000 and of the external pump.

The measurement of an external test leak on a test sample is more accurate when it is measured with and without an added external pump. The ratio of both results is the machine factor.

The machine factor can also be used to correct the leak rate display referred to the air equivalent.

The machine factor for this correction is: 3.7×10^{-1} .

When this setting is used, this status will be displayed by „COR“.

6.11 Menu structure

| | | | | | |
|---------------------|----------------------|---------------------------------|-------------------------------|------------------------------|--|
| Main menu Modul1000 | View | Scale linear/logarithmic | | | |
| | | Display range auto/manual | | | |
| | | Time axis | | | |
| | | Contrast | | | |
| | | Background in standby | | | |
| | | Lower display unit | | | |
| | Mode | | | | |
| | Trigger & Alarms | Trigger level 1 | | | |
| | | Trigger level 2 | | | |
| | | Trigger level 3 | | | |
| | | Volume | | | |
| | | Units | | | |
| | | Alarm delay | | | |
| | | Audio alarm type | | | |
| | | | | | |
| | CAL Calibration | Internal automatic | | | |
| | | Internal manual | | | |
| | | External automatic | | | |
| | | External manual | | | |
| | Settings | Vacuum settings | Purge / Automatic gas ballast | | |
| | | | Vent delay | | |
| | | | Partial flow | | |
| | | | Automatic Leak Test Settings | Measuring time | |
| | | | | Trigger level 1 | |
| | | | | Series Error Messages | |
| | | | | Part Number | |
| | | | | Reference Measurement | |
| | | | Commander functions | Commander Timing | |
| | | | | Commander pressure threshold | |
| | | Background suppression | | | |
| | | Zero & Background | Machine factor | | |
| | | | Leak rate internal test leak | | |
| | | | Background suppression | | |
| | | | zero | | |
| | | Mass | | | |
| Interface | | Control location | | | |
| | | RS232 | | | |
| | | External pressure gauge | Characteristics | | |
| | | | Zero point | | |
| | | | Full scale | | |
| | | Define PLC outputs | | | |
| | | Define PLC inputs | | | |
| Recorder | | Recorder output | | | |
| | | Scale recorder output | | | |
| Others | Output gas ballast | | | | |
| | Time/date | | | | |
| | Language | | | | |
| | Leak rate filter | | | | |
| | Part Number | | | | |
| | CAL setting time | | | | |
| | Maintenance interval | Reset maintenance interval TMP | | | |
| | | Maintenance interval TMP | | | |
| | | Maintenance interval fan filter | | | |
| | | Maintenance message fan filter | | | |

| | | | | |
|---------------------|------------------------|----------------------|-----------------------------------|--|
| Main menu Modul1000 | Settings | Parameter load/save | Save as PARA SET 1 | |
| | | | Save as PARA SET 2 | |
| | | | Save as PARA SET 3 | |
| | | | Load default | |
| | | | Load PARA SET 1 | |
| | | | Load PARA SET 2 | |
| | | | Load PARA SET 3 | |
| | | Monitoring functions | Calibration request | |
| | | | Paging function RC1000 | |
| | | | Contamination protection | |
| | | | Pressure limits for vacuum ranges | |
| | | | Pressure limits for sniff mode | |
| | | | Maximum evacuation time | |
| | Info | View settings | | |
| | | View internal data | | |
| | | Vacuum diagram | | |
| | | Interface | | |
| | | Logged data | View error list | |
| | | | Maintenance history | |
| | | | Calibration history | |
| | | | Test log | |
| Access control | | Clear test log | | |
| | | Calibration factors | | |
| | Services | | | |
| | Access to CAL function | | | |
| | Change device PIN | | | |
| | Change menu PIN | | | |

6.12 Explanation of Menu Items

The menu items on which the explanation refers to are written in bold letters.

Pressing the MENU button displays the selection menu. The software menu opens the menu level which was left before.

If you press the MENU button once more, you can leave the software menu again.

With pressing the MENU button for 2 seconds the display changes to the upper menu level, the Main Menu.

6.12.1 Main menu → Return

Returns to the previous page, does not alter any setting.

6.12.2 Main menu → View

→ **Scale linear / logarithmic**

This setting is for changing the scales of the bar graph and the Y-axis (refer to the chapter Display of Measured Values).

There is the choice of linear and logarithmic presentation. Only in the logarithmic view, the number of shown decades can be changed by pressing the keys "↑" and "↓".

→ **Display range auto / manual**

The upper limit of the displayed bar graph and the diagram can be set manually or automatically.

- **Manually:**
If selected manually, any upper detecting limit between 10^{+3} mbarl/s and 10^{-8} mbarl/s can be set for the bar graph or the Y-axis to show the leak rate graphically.
The lower detecting limit results from the scale setting (refer to chapter "Scale linear/logarithmic")
- **Automatically:**
In the "Automatic"-setting, the bar graph and the Y-axis are automatically adjusted when the value for graphic leak rate presentation is higher or lower.

→ **Time axis**

The length of the time axis in trend mode can be changed in steps from 16 to 960s.

→ **Contrast**

The contrast of the display can be changed. The changes of the contrast are immediately visible. The recommended value under regular conditions is 50 (or close to it).

If the display setting is too light or too dark, so that the menu items cannot be read, the contrast can be reset to the default setting as follows:

- 1 Shut off the Modul1000 and restart it again.
- 2 During the run-up phase, press the key No. 3 or 7 until the display is clearly readable.

This setting is only saved permanently after confirmation in the Contrast menu. If this setting is not confirmed, the former setting will be used for the next start of the Modul1000.

→ **Background in Standby**

In Standby mode, the internal helium background can be displayed.

→ **Lower display limit**

This parameter defines the lower leak rate limit in the measurement ranges. This is valid for vacuum modes only. The lower display limit applies for the graphical diagram of the leak rate and for the numeric output of the leak rate as well. The Modul1000 does not display leak rates below the lower display limit.

The lower display limit can be selected between 1×10^{-5} and 1×10^{-11} mbar l/s.

6.12.3 Main menu → Mode

The operating mode can only be changed in Standby mode.

The following operating modes can be selected:

- **Commander** (refer to chapt. 5.4)
- **Sniffer** (refer to chapt. 5.5)
- **Auto leak test** (refer to chapt. 5.3)
- **Vacuum** (refer to chapt. 5.1)

6.12.4 Main menu → Trigger & Alarms

→ **Trigger Level 1 (2 or 3)**

In this menu item, you have the choice of up to three leak rate trigger thresholds. If the measured leak rate exceeds the set trigger threshold, the Modul1000 reacts as follows:

Display: At the bottom of the display, the symbols for the trigger 1,2, or 3 are displayed in inverted colours.

Relay output: The trigger relay of the PLC-outputs switches over.

Alarm/Loudspeaker: If the trigger threshold 1 is exceeded, an audible alarm signal is generated by the loudspeaker of the Modul1000.

→ **Volume**



Warning

The hearing may be damaged by the alarm signal.
 The noise level of the Modul1000 alarm can exceed 85dB(A).
 Only expose yourself to the alarm signal for a short time or use ear protection.

In the menu item "Volume", it is possible to adjust the volume of the alarm signals by pressing the buttons "↑" and "↓" on the left and on the right of the displayed value. In addition, the volume can also be adjusted during the measurement in the measurement screen using the keys labelled with a loudspeaker sign.

If a minimum sound level is set in the menu item "Volume", it will not be possible to set a lower sound level in the measurement screen or in the menu item "Loudspeaker".

Beep sound: The "Beep On" or "Beep Off" buttons serve for switching On/Off the beep sound of the Modul1000. If the beep is switched on, the Modul1000 indicates certain changes of status by short audio signals.

→ **Units**

The units which are measured by the Modul1000 can be altered.

There is the choice of several pressure units, e.g. mbar, Pa, atm and Torr as well as the leak rate units, e.g. mbar l/s, Pa m³/s, Torr l/s, atm cc/m and atm cc/s.

In Sniff mode, the following additional units are selectable: ppm, g/a, oz/yr.

→ **Alarm delay**

To avoid a trigger alarm due to high background levels, e.g. during the evacuation process, an alarm delay can be set. The alarm delay time will start, after the Modul1000 has changed from the Evacuation mode to the Measurement mode. Trigger 1 will release only then when the set alarm delay time has expired or the measured leak rate was below the set trigger value for a short time.

The alarm delay can vary between zero and ten minutes. If the set time exceeds 10 minutes, the alarm delay time is automatically set to unlimited.

→ **Audio Alarm Type**

There are three optional alarm types.

- Pinpoint:
 The audio signal changes its frequency only within a leak rate window which reaches from one decade below the trigger threshold 1 to one decade above the trigger threshold 1. Below this window, the audio signal frequency remains constantly low and above this range it remains constantly high.
 For example: The trigger limit is 4×10^{-7} mbar l/s. With this, the window reaches from 4×10^{-8} mbar l/s to 4×10^{-6} mbar l/s.
- Leak rate prop.:
 The frequency of the acoustic output is proportional to the reading on the bargraph display. The frequency ranges from 300 Hz to 3300 Hz.

- **Setpoint:**
The frequency of the audio signal is proportional to the value of the leak rate. The audio signal is only generated when the leak rate exceeds the Trigger 1 level.
- **Trigger alarm:**
If the Trigger level 1 is exceeded an audio signal will be generated.

6.12.5 Main Menu → Calibration (CAL) Mode Vacuum

→ *Internal automatic*

If the internal automatic calibration method is selected, the Modul1000 will perform the complete calibration procedure automatically.

In the automatic calibration processes, the Modul1000 runs the following sequences automatically:

- The internal test leak is automatically opened, The inlet is evacuated.
- Measurement of test leak
- Autotune (Calibration to maximum sensitivity of the mass spectrometer)
- The internal test leak is automatically closed, the helium background is measured.
- The newly determined calibration factor is displayed

→ *Internal manual*

If a manual calibration method has been selected, several entries have to be made during the calibration procedure.

- 1** Only for the external manual calibration method, the test leak value has to be entered, when the displayed leak rate does not match with the value of the used test leak. The internal manual calibration already starts with selecting the calibration method.

The value of the used test leak can be entered by pressing the "Change leak rate" button (also refer to chapter "Change values").

After the test leak value has been entered, start the calibration process by pressing the "Start" button.

- 2** After starting the calibration process, the Modul1000 evacuates the inlet area.
- 3** As soon as the maximum intake pressure of the Modul1000 has been reached, first, the Modul1000 displays a varying measuring signal in the shape of a bar display. After a certain time period, which depends on the volume connected to the inlet, the display will stabilize.

As soon as the bar displays a constant value, it has to be acknowledged by pressing "OK".

- 4** In the next step, the Modul1000 adjusts the mass spectrometer to maximum sensitivity.
- 5** Only in case the external manual calibration is required, the Modul1000 will prompt you to close the external test leak.

As soon as the external test leak has been closed, it has to be acknowledged by pressing "OK".

No action will be required for manual internal calibration.

- 6** No entries are required during the running calibration phase.
- 7** In the last step, the Modul1000 saves the newly determined calibration factor.
If the newly determined calibration factor deviates from the prior calibration factor by the factor 2, the new value has to be acknowledged by acceptance.
Press "Yes" and the newly determined calibration factor will be taken over.
Press "No" and the newly determined calibration factor will not be taken over. The Modul1000 will further use the calibration factor determined in the prior calibration procedure.

→ **External automatic**

This requires the connection of an external test leak with solenoid valve.

Once this procedure is started the entire procedure is performed automatically. At the end (after about 25 s) a beep is released. Thereafter the leak detector is ready for further use.

It is possible to set the time before the test leak is opened/closed to receive a constant measuring signal.

→ **External manual**

- 1** Make sure that the test leak is connected and opened.
- 2** Check the leak rate printed on the test leak and compare it with the leak rate at the display. If the leak rates are not identical press *Edit leak rate* and correct the value. If the leak rates are the same, press *START*.
- 3** The bargraph display shows a signal which must not vary much. If so, please press *OK*.
- 4** Close the external test leak and confirm with *OK*.
- 5** The bargraph display shows a signal which must not decrease any more. There might be a small fluctuation which is okay. There If so please press *OK* (Soft Key no. 8).
⇒ The Modul1000 displays the old and the newly calculated calibration factor.

6.12.6 Main menu → Settings

6.12.6.1 Main menu → Settings → Vacuum settings

→ **Purge & Gas ballast**

The following functions are provided in the "Purge & Gas Ballast" menu:

- Manual purge
- Automatic purge
- Manual gas ballast

→ **Vent delay**

Short pressing of "Stop/Vent" causes the Modul1000 to switch back from the Measuring mode to the Standby mode. If you press the "Stop/Vent" button for a longer time, the inlet of the device will be vented additionally.

How long the Stop/Vent button must be pressed to vent the inlet of the Modul1000, depends on the time set in the Delay/Vent menu.

By pressing the respective buttons, you can select one of the optional time periods, "no ventilation", or "immediately". If "no ventilation" is selected, the inlet cannot be ventilated via the Stop-button. If "immediately" is selected, activating the "Stop/Vent" button will immediately switch over to Standby mode.

→ **Partial flow**

In the Partial Flow menu, the Partial Flow mode can be set and configured. It is possible to add the partial flow pump separately only for the Measuring mode and for the evacuation phase.

Main menu → Settings → Vacuum settings → **Auto Leak Test Settings**

→ **Measuring time**

This software menu serves for specifying the measuring time in Auto Leak Test. The possible time settings range from 1 second to 30 minutes.

→ **Trigger Level 1**

The software menu Trigger level 1 is for setting the rejection leak rate for the Auto Leak Test.

→ **Series error messages**

In the software menu "Series error messages" serves for activating the series error message and the number of consecutive "FAIL" messages which shall cause the series error message.

→ **Part number**

In the Part number menu, the part counter can be activated and a start value can be set from which the counting will start after each test cycle.

→ **Reference measurement**

In this menu, the reference measurement can be started.

Main menu → Settings → Vacuum settings → **Commander Functions** →

In the menu item „Commander Functions“, all parameters of the commander function can be configured.

→ **Commander Timing**

The individual process times can be set here.
The adjustment range is from 0.1 to 95 seconds

t_A evacuation time

Maximum time to achieve the set sample pressure "p_B evacuation pressure"
Default setting: 30 seconds

t_B zero delay

Time delay until ZEROING (if zero "enabled") or time in which I-ZERO is carried out (if I-ZERO has been activated);
Default setting: 10 seconds

t_C filling time

Maximum time to achieve the filling pressure "p_C Filling pressure" in the unit under test
Default setting: 30 seconds

t_D depressurising time

Maximum time to achieve the set depressurising pressure "p_B evacuation pressure"
; factory setting: 30 seconds

t_E flooding time

Maximum time to achieve the set flooding pressure p_A gross leak test
; factory setting: 10 seconds

t_F readiness for measuring

Maximum time to achieve the Measuring mode
; factory setting: 10 seconds

t_G measuring time

Time, after which the leak rate signal has been balanced.
; factory setting: 10 seconds

→ **Commander Pressure Threshold**

p_A initial leak test

Lowest pressure to which the unit under test may drop

; factory setting: 900 mbar

p_B evacuation pressure

Pressure to which the unit under test is evacuated

; factory setting: 40 mbar

p_C fill pressure

Pressure to which the unit under test is filled with helium

; factory setting: 2000 mbar

p_D depressurising pressure

Pressure to which the helium is released from the unit under test

; factory setting: 1100 mbar

p_E pressure fall threshold

Minimum permissible pressure of the unit under test during leakage rate measurement

; factory setting: 1800 mbar

Main menu → Settings → Vacuum settings → **Machine factor**

After internal calibration, the machine factor considers the relation between the effective pumping speed of the Modul1000 and of the system pump stand in measuring mode.

The machine factor takes into account that an additional external pumping system is used.

Because internal calibration does not take into account the sharing of helium in partial flow mode, all measured leak rate would be measured too small.

The measured leak rates are multiplied with the machine factor and the result is displayed. This factor is only used for vacuum mode (not for sniff mode).

The machine factor can be estimated under consideration of both, the helium pumping speed of the Modul1000 and the external pump.

The measurement of an external test leak on a unit under test is more accurate when it is measured with and without an added external pump. The machine factor is defined by the difference between the results.

The machine factor can also be used to correct the leak rate display referred to the air equivalent. The machine factor for this correction is 3.7×10^{-1} .

When the machine factor does not equal 1, this status will be displayed by „COR“.

Main menu → Settings → Vacuum settings → **Leak rate internal test leak**

The value of the internal test leak can be set here.

6.12.6.2 Main menu → Settings → Zero & Background

→ **Background suppression**

Inlet area: In addition to the internal background, after activating the START button also the background of the inlet area will be deducted from the measured signal. The value has to be determined using the „Background definition of inlet area“ function in the „Zero & Background“ menu.

Internal only: The internal background is measured with the activation of the START button and is deducted from the measured signal.

→ **Background definition Inlet Area**

The device must comply with the following conditions for this function:

- Vacuum mode
- Vented status (at least 1 minute)
- Inlet port blanked off
- At least 20 minutes have passed since the device was switched on.

→ **Zero**

The function **I•Zero** allows to enable the ZERO button only when the leak rate signals are stable. In this setting, the inclination of the decreasing background signal is measured. The leak rate signal must be stable enough to detect a leak of the programmed size of Trigger 1. The **I•Zero** function is locked as long as the leak rate signal is not stable enough. (The inclination of the dropping background signal is $> 0.5 \times$ set Trigger level 1.)

6.12.6.3 Main menu → Settings → Mass

In the "Mass" menu, the tracer gas used for leak detection can be changed. The following gases are available:

- H₂ (hydrogen)
- He (helium)
- ³He (helium isotop with mass 3)

6.12.6.4 Main menu → Settings → Interfaces

In the "Interfaces" menu, the electric interfaces of the Modul1000 can be configured.

Main Menu → Settings → Interfaces → Control location

→ **PLC**

The Modul1000 is controlled via the digital input. The START, STOP and ZERO buttons of the device are disabled.

→ **RS232**

The Modul1000 is controlled via RS232 interface by an external computer. In this mode, the Modul1000 cannot be controlled via the keyboard.

→ **All**

Control interfaces PLC, RS232 and Local

→ **Local and PLC**

The Modul1000 is controlled via the START, STOP and ZERO buttons on the device and via the digital inputs.

→ **Local and RS232**

The Modul1000 is controlled via the START, STOP and ZERO buttons on the device and via the digital inputs.

→ **Local**

The Modul1000 is controlled via the START, STOP and ZEROR buttons.

Main menu → *Settings* → *Interfaces* → **RS232**

→ **Local**

Without request, the leak detector continuously sends the status and the leak rate.

→ **Binary**

Allows reading of equipment parameters, e.g. during maintenance.

→ **UL2xxLeak Ware**

Allows controlling and reading of measured values when connected to a computer. (For operation of the Leak Ware refer to the corresponding operating instructions).

Notice: The calibration function of the Leak Ware cannot be used for the Modul1000. Please execute the function „STORE DATE“ in the operating mode „Single Part Measurement“ for recording the measured values.

→ **ASCII**

Enables the operation of the Modul1000 via an RS232 terminal. For further details refer to Interface Description.

*Main Menu → Settings → Interfaces → **External Pressure Gauge***

In Commander mode, the Modul1000 has to be connected to an external pressure gauge. In the "External pressure gauge" mode is for setting the characteristics and the zero-point, as well as full scale of the used pressure gauge.

- **Characteristics:** The following characteristics can be set: current linear, voltage linear, current logarithmic, voltage logarithmic.
- **Zero point:** The zero point (pressure value) of the connected sensors can be assigned with the corresponding current or voltage value.
- **Full scale:** The full scale (pressure value) of the connected sensors can be assigned with the corresponding current or voltage value.

*Main Menu → Settings → Interfaces → **Define PLC Outputs***

In this sub-menu, the pin assignment of the PLC output connector (PLC-OUT) can be changed.

To assign the PLC outputs proceed as follows:

- 1** Select the connecting pin of the connector PLC-OUT to be changed using the left arrow key
- 2** The right arrow key serves for assigning the selected pin to one of the listed functions.
- 3** After the PLC outputs have been assigned as desired, confirm the settings by pressing the OK button.

*Main Menu → Settings → Interfaces → **Define PLC Inputs***

In this sub-menu, the pin assignment of the PLC input connector (PLC-IN) can be changed.

To assign the PLC inputs proceed as follows:

- 1** Select the connecting pin of the connector PLC-IN to be changed using the left arrow key
- 2** The right arrow key serves for assigning the selected pin to one of the listed functions.
- 3** After the PLC inputs have been assigned as desired, confirm the settings by pressing the OK button.

The PLC inputs and the PLC outputs can be inverted in the menu via the serial interface. The inverting is also be saved in the parameter sets.

*Main Menu → Settings → Interfaces → **Recorder***

In this sub-menu, the signals to be recorded by the recorder can be assigned to the two recorder outputs (analogue outputs).

→ Recorder output

Refer to chapt. 9.4 Analogue output (Recorder output).

→ Scaling **Recorder Output**

Here the scaling of the recorder output can be adjusted. This adjustment is only valid for the setting of "LR lin" or "LR log".

By pressing the arrow keys on the right and on the left of the value for the "Upper limit", the upper display limit of the analogue output can be set.

By pressing the arrow keys on the right and on the left of the value for "scaling", the scale division can be set in steps of 0.5, 1, 2, 2.5, 5, 10 V/decade, whereby the full scale will be 10V. (For "LRlog" only)

Example for signal LRlog:

- 1 The upper limit value is set to 10^{-5} (=10 V)
- 2 Scaling is set to 5 V/decade

With this,⇒ the lower limit is at 10^{-3} (= 0 V)

Main Menu → Settings → Interfaces → **Gas ballast output** →

- inverted:
Output level HIGH with closed gas ballast/purge valve
- Standard:
Output level HIGH with opened gas ballast/purge valve

6.12.6.5 Main menu → Settings → Miscellaneous

→ **Date / Time**

Set time and date, if necessary.

→ **Language**

The optional languages German, English, Italian, French, Polish, Katakana, Chinese, Spanish can be selected.

The default language is English.

If accidentally a wrong language has been set, English can be set during the run-up of the Modul1000 after it has been switched on, when the buttons 2 and 6 are simultaneously pressed.

The settings are not saved automatically but have to be saved via this menu item.

→ **Leak rate filter**

The kind of the leak rate filter can be chosen. The default value is I•CAL.

The abbreviation I•CAL stands for Intelligent Calculation Algorithm for Leak rates. It makes sure that the signals are averaged in optimized time intervals, based on the leak rate intensity. I•CAL also eliminates noise peaks which are not related to leak rate signals and provides unexpected short response times for low leak rate signals.

The algorithm used provide excellent sensitivity and response time and is there for the recommended setting.

The filter type Fixed uses a fixed time for averaging of 0.2 seconds.

→ **Partnumber**

This menu serves for enabling the automatic counting of parts to be tested.

→ **CAL Transient time**

This menu is used to set how long it takes from the opening the test leak valve to the measuring of the steady-state signal when it is automatically calibrated internally and externally. This times depends on the volume which is on the inlet during calibration.

→ **Maintenance intervals**

→ **Reset the maintenance interval TMP** It resets the maintenance interval of the turbo-molecular pump (refer to chapter 7 Maintenance Works)

→ **Maintenance message for TMP** This menu item „maintenance message for TMP“ serves for resetting the maintenance messages, which appear automatically after the maintenance interval has expired.

→ **Maintenance Interval Fan Filter** In the Maintenance Interval Fan Filter menu, the maintenance interval can be defined in steps of 500 h. The highest value is 4000 hours. If the percentage of dust in the air at the measured site very high, the interval should be short.

→ **Maintenance message Fan Filter** This menu item „Maintenance Message Fan Filter“ serves for resetting the maintenance messages, which appear automatically after the maintenance interval has expired.



Warning

If the maintenance message is ignored and the contaminated filter is not replaced, there will be the risk of overheating for the Modul1000.

6.12.6.6 Main menu → Settings → Load/Save Parameters

→ **Save in “PARA SET 1”**

→ **Save in “PARA SET 2”**

→ **Save in “PARA SET 3”**

By pressing the buttons "Save in PARA SET 1" to "Save in PARA SET 3", the current menu settings can be saved in the Modul1000.

On the now appearing menu screen, the saved parameter set can be renamed by pressing the "Edit name" button.

→ **Load in “PARA SET 1”**

→ **Load in “PARA SET 2”**

→ **Load in “PARA SET 3”**

Pressing the buttons "Load PARA SET 1" to "Load PARA SET 3" loads the before saved parameter sets and enables them.

→ **Load default values**

The "Load default values" button serves for loading of one of the four factory-provided parameter sets

| | Default Parameter set 1 | Default Parameter set 2 | Default Parameter set 3 | Default Parameter set 4 |
|------------------|----------------------------|----------------------------|----------------------------|----------------------------|
| PLC IN Pin 3 | START | START_STOP | START | START/STOP |
| PLC IN Pin 4 | STOP | GAS BALLAST | STOP | CAL |
| PLC IN Pin 5 | ZERO | ZERO | ZERO | ZERO ON |
| PLC IN Pin 6 | CAL | CAL | INV GAS BALLAST ON | |
| PLC IN Pin 7 | CAL INTERN | CLEAR | GAS BALLAST OFF | |
| PLC IN Pin 8 | CAL EXTERN | NOT USED | NOT USED | |
| PLC IN Pin 9 | CLEAR | NOT USED | NOT USED | |
| PLC IN Pin 10 | GAS BALLAST | NOT USED | NOT USED | |
| | | | | |
| PLC OUT Pin 3 | TRIGGER 1 | Error | MEASURE | EMISSION ON |
| PLC OUT Pin 4 | TRIGGER 2 | WARNING | Error | INV TRIGGER1 |
| PLC OUT Pin 5 | TRIGGER 3 | EMISSION ON | MEASURE | INV TRIGGER2 |
| PLC OUT Pin 6 | ZERO ACTIVE | CAL ACTIVE | EMISSION ON | INV ERROR |
| PLC OUT Pin 7 | EMISSION ON | GAS BALLAST | GAS BALLAST | |
| PLC OUT Pin 8 | Error | CAL REQUEST | TRIGGER 1 | |
| PLC OUT Pin 9 | CAL ACTIVE | MEASURE | TRIGGER 2 | |
| PLC OUT Pin 10 | CAL REQUEST | ZERO ACTIVE | TRIGGER 3 | |
| PLC OUT Pin 11 | OPEN | TRIGGER 1 | OPEN | |
| PLC OUT Pin 12 | OPEN | TRIGGER 2 | OPEN | |
| PLC OUT Pin 13 | OPEN | TRIGGER 3 | OPEN | |
| PLC OUT Pin 14 | OPEN | REC STROBE | OPEN | |
| | | | | |
| RECORDER Pin 2 | LR MANTISSA | LR MANTISSA | LR MANTISSA | |
| RECORDER Pin 3 | LR EXPONENT | LR EXPONENT | LR EXPONENT | |
| | | | | |
| LR-UNIT | mbar/s | Pa m³/s | Pa m³/s | Pa m³/s |
| Pressure Unit | mbar | Pa | Pa | Pa |
| Control location | LOCAL | LOCAL, PLC | LOCAL, PLC | LOCAL, PLC |

Default setting: Parameter set 1

6.12.6.7 Main menu → Settings → Monitoring

→ **Calibration Request**

It can be selected whether the operator is reminded of the fact that a calibration may have become necessary or not. The default setting is "Off".

If the calibration request is switched on, a corresponding message will appear when 30 minutes have elapsed after power on or if the temperature of the Modul1000 has changed by more than 5°C since the last calibration.

→ **Paging Function**

If the Modul1000 has a wireless remote control RC1000WL, an audio signal can be enabled which sounds on the remote control to find it and to identify it.

→ **Contamination protection**

If this mode is switched on, the Modul1000 closes all valves as soon as the measured leak rate exceeds the value limited by the contamination protection. Thus no more Helium gets into the mass spectrometer. Helium contamination of the leak detector will be avoided.

→ **Pressure limit for vacuum area**

In this menu, the factory-set switching point from evacuation to measurement mode ULTRA can be programmed. This can be necessary when the Modul1000 shall evacuate other gases than air. The pressure signal of the gas-type-depending Inlet pressure indication (Pirani) can then provide other values to the process control for switching over. This can be adjusted by changing the switching points.

Default setting: 0.4 mbar (Modul1000) or 3 mbar (Modul1000b)

→ **Pressure limit for Sniff mode**

This function is automatically activated in sniff mode. The pressure limits define an upper and lower limit of the inlet pressure. If the pressure is not in this range, the following error messages/warnings will be generated:

Fore-vacuum pressure > Maximum pressure: Error message E63 (Capillaries defective)

Fore-vacuum pressure > Minimum pressure: Warning W62 (Gas flow through capillaries too low).

→ **Maximum Evacuation time**

This menu item is used to define when the gross leak message is to occur. The gross leak detection process operates in two steps and the limits can be adapted as required.

This menu item is particularly useful in series testing under the same conditions at all times.

After pressing the start button the test sample is evacuated.

If the required pressure conditions are not achieved within the time to be set here, or they are not below the set values ($p_1 < 100$ mbar or $p_1 <$ pressure limit for vacuum areas), the evacuation process will be interrupted and a warning message will appear on the display. (W75 or W76)

On the one hand, the selected periods depend on the desired reaction time for the gross leak message, and on the other hand, they depend on the volume of the test sample and the effective pumping speed.

If the evacuation time was set to endless, the oil level of the rotary vane pump should be checked more frequently.

6.12.7 Main menu → Info

→ **View settings**

In this screen, you can see the most important measurement settings.

→ **View internal Data**

This menu point spans across several pages to show all kinds of internal data.

→ **Vacuum diagram**

The vacuum diagram of the Modul1000 is displayed. Opened and closed valves are also shown. In Partial Flow mode and when the Commander functions are used, the corresponding vacuum diagrams are displayed on the menu screen.

→ **Interfaces**

This menu item includes an overview over the interfaces (configuration and status).

→ **Recorded Data**

This screen can display the history of errors, maintenance works and tests. (Refer to 6.8)

→ **Calibration Factors**

The calibration factors for the several masses or operating modes and the machine factor are displayed.

→ **Service**

This menu item is only accessible for authorized INFICON service personnel.

Main menu → Info → Recorded Data

→ **View error list**

The last 12 occurred errors are listed.

→ **Maintenance List**

The dates of the last 12 maintenance services are displayed.

→ **View Calibration History**

Data of the last 12 calibration procedures is displayed.

→ **Test Log**

The test log are saved in case the part number has been enabled.

→ **Clear Test Log**

The saved test logs can be deleted.

6.12.8 Main menu → Access Control

→ Access to CAL-Function

Here, you can lock and unlock the access to the calibration function.

→ Change DevicePIN

The access to the Modul1000 can be restricted by entering or editing the Device-PIN. Is the Device-PIN not 0000, the Modul1000 will request this PIN immediately after switching on. Without Device-PIN the Modul1000 cannot be started.

→ Change Menu PIN

Here, you can set and change a 4 digit PIN to lock the access to the menu via the control unit.

7 Maintenance tasks

The Modul1000 is a measuring device specifically designed and built for industrial use. The components and assemblies used correspond with the highest quality standards and are generally need low-maintenance.

However, to maintain the warranty claim for the Modul1000 it is required, to keep the maintenance intervals as listed below:

It is recommended signing a maintenance contract for the Modul1000 with INFICON or a service partner authorized by INFICON.

7.1 Maintenance and service at INFICON

If an equipment is returned to INFICON, indicate if the equipment is free of substances damaging to health or if it is contaminated. If it is contaminated, indicate the nature of the hazard. Use a form prepared by us for "contamination declaration", which we will submit to you upon request. You will find a copy of the form at the end of the technical manual. Copies of the form are also permitted.

Attach the form directly to the equipment or put it into the packaging with the equipment!

Notice: The "contamination declaration" is required to meet legal requirements and protect our employees. If the equipment has no Declaration of Contamination attached, INFICON must return any equipment to the sender's address.

7.2 General Maintenance Instructions

Maintenance work for the Standards is divided into 3 service segments:

- Service segment ICustomer
- Service segment IICustomer with technical education
- Service segment IIIauthorized INFICON service technician

Maintenance work of service segment III may only be performed by persons authorized and trained by INFICON GmbH in Cologne.

Please observe the following safety instruction for all maintenance work on the Standards!



Danger

For all maintenance works on the Modul1000, the leak detector must be disconnected from the power supply.



Caution

Make sure the tools and the vicinity by working on vacuum systems are kept clean.

The Modul1000 has three maintenance counters which run independently from each other. In detail:

- 1** Maintenance counter for air filter:
The default setting is 2500 operating hours. The maintenance counter can vary or it can be switched off. In this way, it can be adjusted to the operating conditions of the device.
- 2** Maintenance counter 5000 operating hours:
It serve for the inspection and cleaning of valve drives and the valve block.
- 3** Maintenance counter for 2 years
It is intended for the maintenance of the turbo-molecular pump TMH 071.

When the before mentioned maintenance intervals have expired, the control unit of the Modul1000 will display a warning every time the device is switched on. The message appears as long as the maintenance interval has been acknowledged. The maintenance counter 2 is only enabled for the service steps II and III in the service menu.

Notice: To be able to claim for compensation for damage, the maintenance schedule of the Modul1000 has to be observed. If necessary maintenance works were not done, the claim for compensation for this component will expire.

Fore Pump

The fore-vacuum pump is not included in the scope of delivery for the equipment. Therefore, the maintenance intervals and the instructions required by the manufacturer of the fore-pump will be applied.

Damages on the Modul1000, which are clearly traceable to a malfunction of the fore pump, cannot be claimed for compensation.

7.3 Maintenance schedule

| Assembly | Maintenance tasks Standards | Operating hours/Years | | | | Service segment | Spare Part No. |
|----------------------|---|-----------------------|----------------|----------------|----------------|--------------------|-------------------|
| | | 1500 | 5000 | 15000 | | | |
| | | 1/4 | 1 | 2 | 3 | | |
| Vacuum system | | | | | | | |
| Valve block | Clean the valves, replace seals for valves | | X ₁ | | | III | 200000594 |
| | Take apart the valve bloc and clean it | | | X ₁ | | III | 200002002 |
| | Replace the filter of the flood gas line | | 1 | X ₁ | | I, II,III | 200000683 |
| | Adjust the Pirani | | | X | | III | |
| | Recalibrate the internal test leak | | X ₂ | | | | |
| TMH 071 | | | | | | | |
| | Replace the lubricant reservoir | | | X ₂ | | I, II and III | 200000577 |
| | Change the bearings (recommended) | | | | X ₂ | III | |
| Electric | | | | | | | |
| Fans assembly | Replace the filter inserts of the cover | 1 | X ₁ | | | I | 200001552 |
| | Clean the fan, chassis and turbo-molecular pump | 1 | X ₁ | | | I | |

Legend for the Maintenance Schedule

- I Service segment I Customer
- II Service segment II Customer with INFICON training
- III Service segment III authorized INFICON service technician
- X Perform maintenance work according to operating hours or time
- X₁ Perform maintenance work according to operating hours
- X₂ Perform maintenance work according to time
- 1 depending on the environment and use
- 2 Relevant to the process

7.4 Maintenance intervals

The maintenance schedule for the Modul1000 can be subdivided in 4 maintenance groups.

- 1500 hours maintenance
- 5000 hours maintenance
- Maintenance every two years

1500 hours -Maintenance

The 1500 hours maintenance can be performed by an operator or a maintenance person. The maintenance intervals can be adapted to the ambient conditions of the device and are variable.

If desired, the maintenance interval can be switched off.

Within the 1500-hours maintenance, the filter inserts in the chassis cover have to be inspected and if contaminated, replace them. The filter inserts can be replaced on the running device without the need to open it.

For replacement refer to Fig. 7-1.

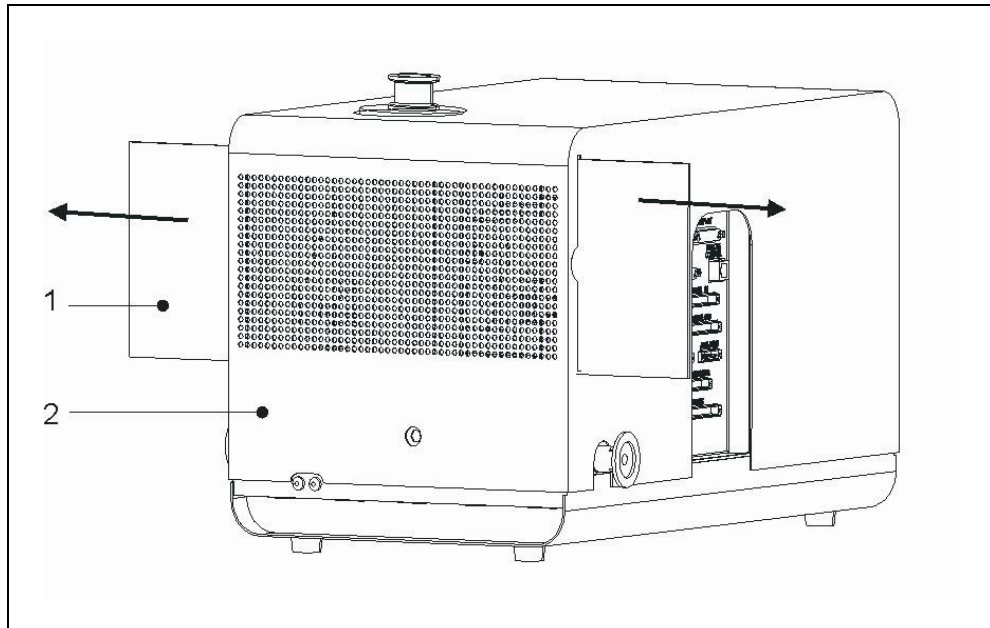

Fig. 7-1 Remove the filters form the chassis housing.

| Item | Description | Item | Description |
|------|---------------|------|-------------------|
| 1 | Filter insert | 2 | Chassis Modul1000 |

| Work to be performed | Required materials | P/N |
|---------------------------|----------------------------------|-----------|
| Check/replace air filters | • Spare Filter Cell for the fans | 200001552 |

5000 hours -Maintenance

The 5000 hours maintenance should be performed by an INFICON service technician or an other person authorized by INFICON.

The valve drives have to be inspected and cleaned every 5000 operating hours and the valve seals or the valve caps have to be replaced. The flood filter needs to be inspected after 5000 hours depending on the application, however it will be necessary to replace it after 15000 operating hours.

After 15000 operating hours, a complete cleaning of the valve block will be required. This requires the disassembly of the valve block.

Notice: The certificate of the internal helium standard leak is valid for one year after delivery. The annual refurbishing of the internal Helium standard leak is recommended and an other certificate will be delivered. In the procedure, all functions of the internal helium standard leak are checked and a new certificate is released for the next year.

| Work to be performed | Required materials | P/N |
|---|--|-----------|
| Clean the valve drives, replace the valve seals and the valve caps (5000 hours) | <ul style="list-style-type: none"> Set of seals for valves | 200000594 |
| Check/replace vent filters (5000/15000 h) | <ul style="list-style-type: none"> Spare filter for venting and purge line | 200000683 |
| Clean the valve block completely (15000 h) | <ul style="list-style-type: none"> Sealing set of detection system complete | 200002002 |
| Recalibrate the internal test leak (recommended yearly) | | |
| Inspection and recalibration of Pirani sensors (15000 h) | | |

2-years Maintenance Operating fluid reservoir TMH 071

The 2-years-maintenance of the operating fluid reservoir of the turbo-molecular pump TMH 071 should be performed by a INFICON service technician or by a person authorized by INFICON. Customers who have received pertinent instructions from an authorized person can perform maintenance at their own responsibility.

The operating fluid reservoir of the turbo-molecular pump TMH 071 must be replaced after 2 years, regardless of the operating hours achieved. Please follow the instructions in 7.6 when replacing the operating fluid reservoir.

| Work to be performed | Required materials | P/N |
|---|---|-----------|
| Replace the operating fluid reservoir TMH 071 | <ul style="list-style-type: none"> Operating fluid reservoir for TMH 071 | 200000577 |

7.5 Description of the maintenance work

Only trained specialist staff may modify the Modul1000 in a way that exceeds the standard scope of maintenance.

For maintenance works described in this chapter it will not be required to remove the cover of the device. However the replacement of fuses requires the device to be opened. To exclude possible danger in this case, follow the described procedure:

7.5.1 Opening of the Device

Required Tools

Allen wrench 8 mm

STOP
Danger

Before removing the cover of the device you must disconnect the leak test device from the mains cord.

Open the Modul1000 as follows:

- 1** Switch off the line switch and remove the power cable.
- 2** Remove the clamp ring for quick release.
- 3** Use the Allen wrench SW 8 mm and open the locks (ROTO-LOCK) on both sides of the device cover. Refer to [Fig. 7-2](#).

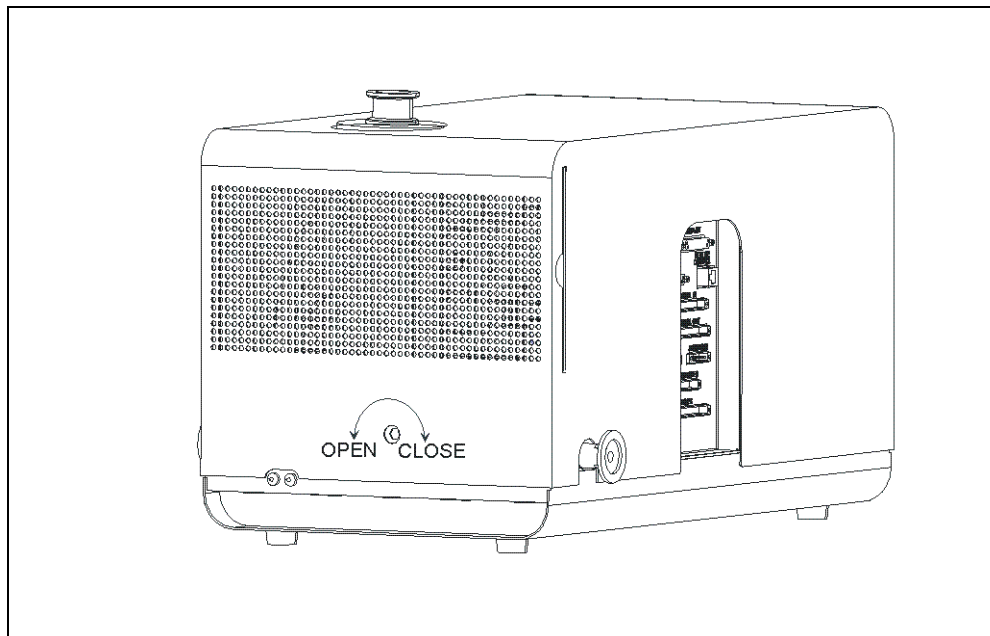

Fig. 7-2 Open the cover

- 1** Turn the Roto-Locks until they reach their end positions „OPEN“.
- 2** Carefully lift the cover.
- 3** The cover is reassembled in reverse order. When attaching the cover ensure that no electrical wires reach between the cover and the chassis.
- 4** To secure the cover, turn the Roto-Locks until they reach their end positions „CLOSE“.

7.6 TMH 071 Replace the Lubricant Reservoir

The turbomolecular pump TMH 071 is filled with operating fluid for the lubrication of the ball bearings. The lubricant reservoir has to be replaced every two years, no matter if the operating hours are reached. The lubricant reservoir must be replaced at shorter intervals under extreme loads of the TMH 071 or in unclean processes.

Required Tools

Special tool - calliper face spanner

Required material

operating fluid reservoir P/N: 200 000 577



Warning

Prior to starting maintenance work, please verify that the mass spectrometer and the turbo-molecular pump are completely flooded. The cover for the lubricant reservoir can only be removed in the flooded state.

- 1 For flooding the TMH 071 disconnect the fore vacuum connection to the Standards and switch the device on for about 10 to 25 s. After about 10 s, valve V2 opens and the mass spectrometer and the turbo-molecular pump are flooded. Further wait for at least 10 s until the high vacuum system is completely flooded.
- 2 Switch the mains switch Off again and disconnect the device from the power supply.
- 3 Turn the device and place it on its long side to access the inspection port on the bottom.

Notice: Make sure not to damage the fore-vacuum connections.

- 4 To be able to replace the lubricant reservoir of the turbo-molecular pump, the cover at the bottom of the TMH 071 has to be unscrewed. Refer to [Fig. 7-3/3](#).

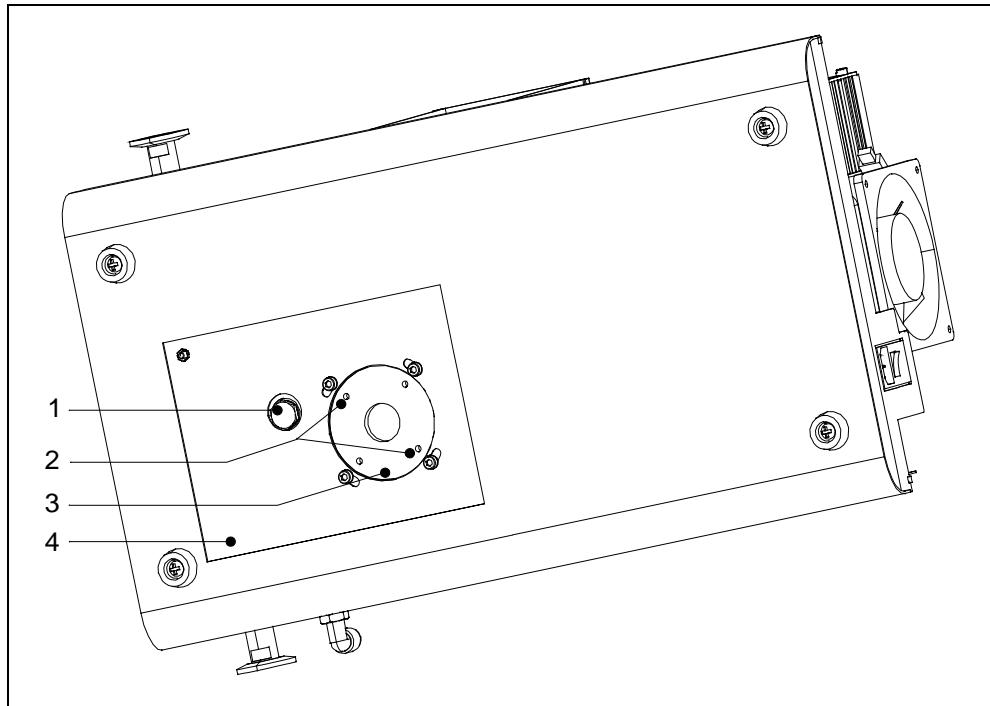

Fig. 7-3 Cover of the lubricant reservoir TMH 071

| Item | Description | Item | Description |
|------|-------------------------|------|--|
| 1 | Fore-vacuum connection | 3 | Cover of the lubricant reservoir TMH 071 |
| 2 | Pocket for special tool | 4 | Inspection port |

- 5 Unscrew the cover on the bottom of the TMH71 using a special tool (calliper face spanner).
- 6 After removing the cover, the lubricant reservoir will be accessible. Pull out the lubricant reservoir using a screwdriver and dispose it off according to local regulations.
- 7 Insert new lubricant reservoir.
Refer to [Fig. 7-4](#).



Caution

Do not press the lubricant reservoir completely in. The lubricant reservoir is properly positioned by twisting in the cover. Also refer to the Operating Manual Differer PM 800 504 BN.

- 8 Replace the O seal ([Fig. 7-4/2](#)) by a new O-seal. Verify that the new O-ring is inserted in the proper position. An incorrectly inserted O-ring may cause large leaks and the malfunction of the equipment.
- 9 Then assemble and tighten the cover.

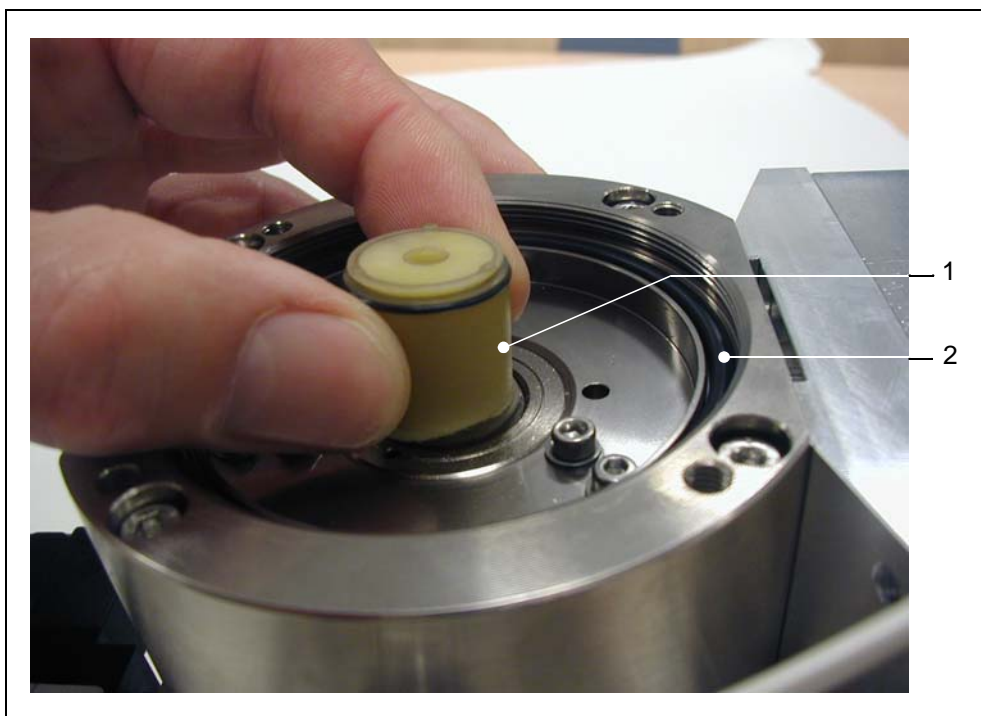

Fig. 7-4 Replace the Lubricant Reservoir

| Item | Description | Item | Description |
|------|---------------------------|------|-------------|
| 1 | Operating fluid reservoir | 2 | O-Ring |

7.7 Fuse replacement

7.7.1 Overview on Electrical Fuses

Mains switch housing chassis:

| Designation | Technical data | Fuse for |
|--------------|----------------|--------------------------------------|
| Mains switch | 2 x T 6.3 A | Power supply unit fuse (2-phase OFF) |

Wiring plane:

| Designation | Technical data | Fuse for |
|-------------|----------------|--------------------------|
| F10 | T 6,3 A | Power supply unit TC 600 |
| F11 | T 0,8 A | Fans |

Power supply unit ZWS240PAF-24/TA:

| Designation | Technical data | Fuse for |
|-------------|----------------|------------------------|
| F1 | F 6.3 A | Fuse power supply unit |

I/O PCB:

| Designation | Technical data | Fuse for |
|-------------|----------------|----------|
| F1; F2 | T 0,8 A | not used |
| F3 | T 0,315 A | not used |

Circuit board MSV:

| Designation | Technical data | Fuse for |
|-------------|----------------|-------------------------------|
| F1 | T 2 A | 24 V main fuse for MSV card |
| F2 | T 3,15 A | Anode heater (no use) |
| F3 | T 1 A | 15 V; +5V DC/DC transformer |
| F4 | M 0.032 A | Anode- cathode voltage (85 V) |

Interface board:

| Designation | Technical data | |
|-------------|----------------|---|
| F1 | T 1 A | 24 V CONTROL UNIT |
| F2 | T 0,8 A | 24 V REMOTE CONTROL; PC RS232 |
| F3 | T 0,8 A | 24 V PRESSURE GAUGE, PLC IN |
| F4 | T 1,6 A | 24 V PLC OUT; VALVES; ACCESSORIES |
| F5 | T 1,0 A | VALVES V30...V33 supply voltage (max. 30 V) |
| F6 | T 1,0 A | VALVES V34...V37 supply voltage (max. 30 V) |

Notice: Please note that this work is only performed by skilled electricians, since generally a cover of an electric module may have to be opened.

7.7.2 Replace mains fuse

STOP Danger

Danger of fatal injuries due to electric shock.
 Before replacing the fuse, disconnect the power plug of the Modul1000.
 Only insert fuses with the specified values in the Modul1000.

Required Tools

- Screwdriver size 1

Required material

- Safety fuse 2xT 6.3A

The main fuses of the Modul1000 are housed in the mains switch of the equipment.

- For replacing the main fuses, open the cover of the fuse insert using a screwdriver. For this, insert the screwdriver into the respective groove and open the cover. Refer to Fig. 7-5.

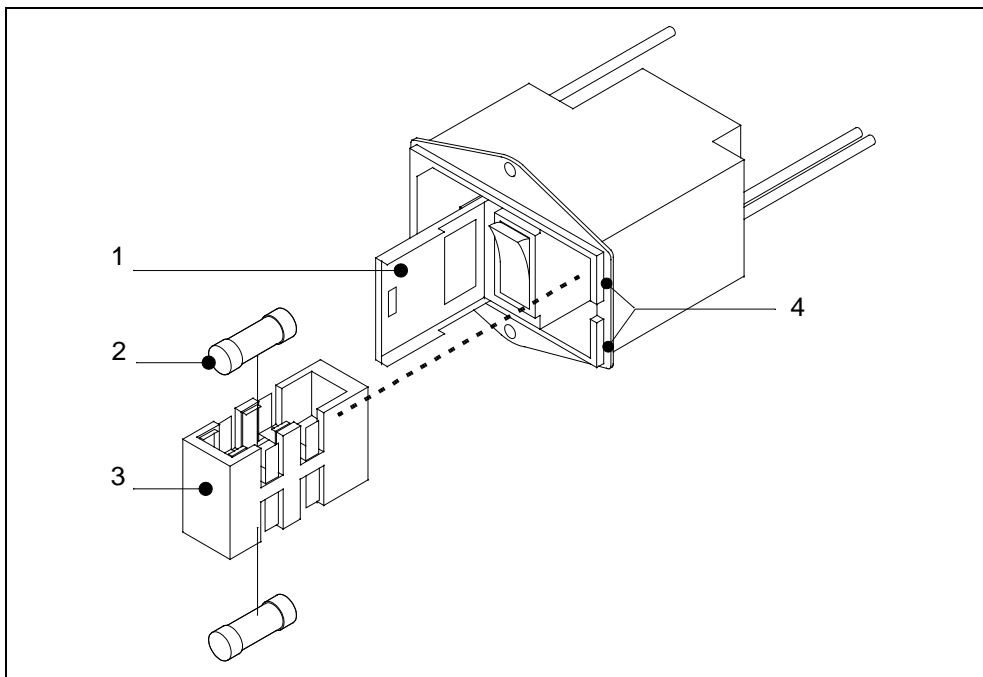

Fig. 7-5 Fuse replacement

| Item | Description | Item | Description |
|------|--------------------|------|-----------------|
| 1 | Cover | 3 | Fuse insert |
| 2 | Safety fuse T 6.3A | 4 | Groove openings |

7.7.3 Replace fuses on interface board

The interface board (SSK) includes the fuses for the inputs and outputs on the board. Please find an overview on the fuses and their purpose in [7.7.1 Overview on Electrical Fuses](#).

Required Tools

- Allen key SW 8

Required material

- Complete set of fuses Order No.: 200 000 641

Access to the fuses is only possible when the cover of the Modul1000 has been removed. Follow the instructions in [7.5.1 Opening of the Device](#).

Notice: Please observe the safety instructions in this chapter.

- After the cover has been removed, the fuses on the interface board are accessible. Refer to [Fig. 7-6](#).

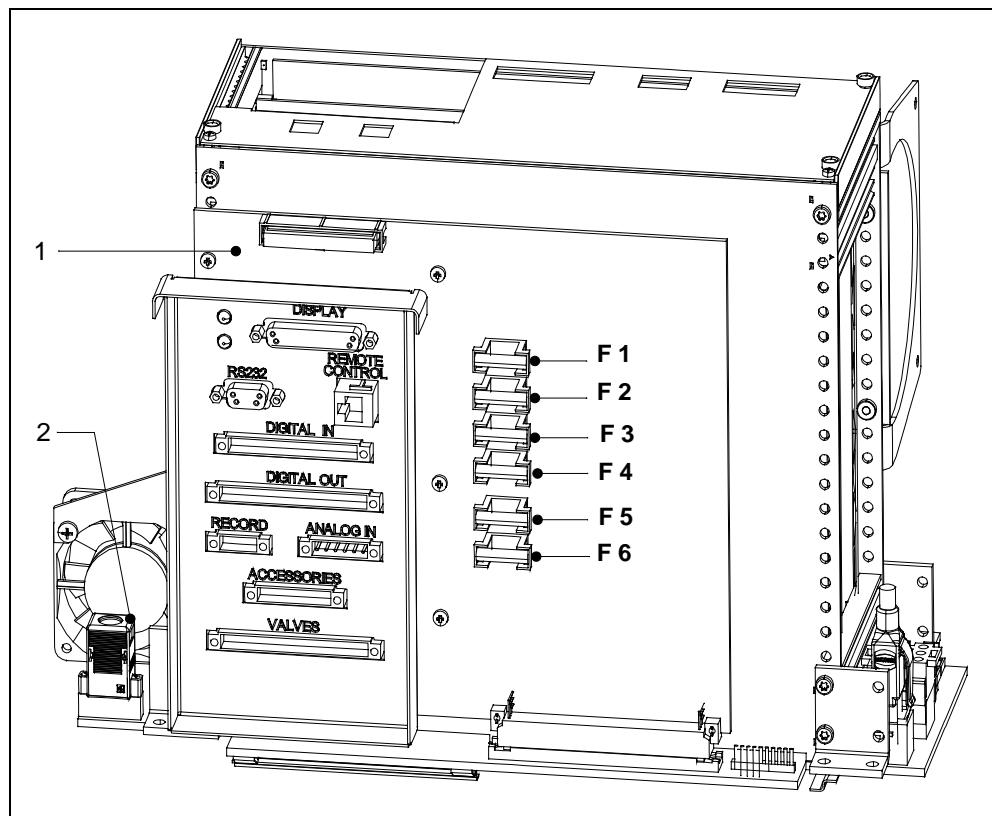

Fig. 7-6 Fuses on interface board (SSK)

| Item | Description | Item | Description |
|------|---------------------|------|-------------|
| 1 | Interface board SSK | 2 | I-STICK |

7.8 Replacing of parameter memory (I•STICK)

The customer's application parameters are also stored in I•STICK. If a backup unit is required, the application parameters can easily be transferred by connecting the I•STICK to the backup unit.

Required Tools

- Allen key SW 8
- Screwdriver size 1

Required material

- I•STICK

Access to the I•STICK is only possible when the cover of the Modul1000 has been removed. Follow the instructions in [7.5.1 Opening of the Device](#).

Notice: Please observe the safety instructions in this chapter.

- To replace the I•STICK, release the two screws with which the I•STICK is screwed on the connector. See the [Fig. 7-7](#) below.

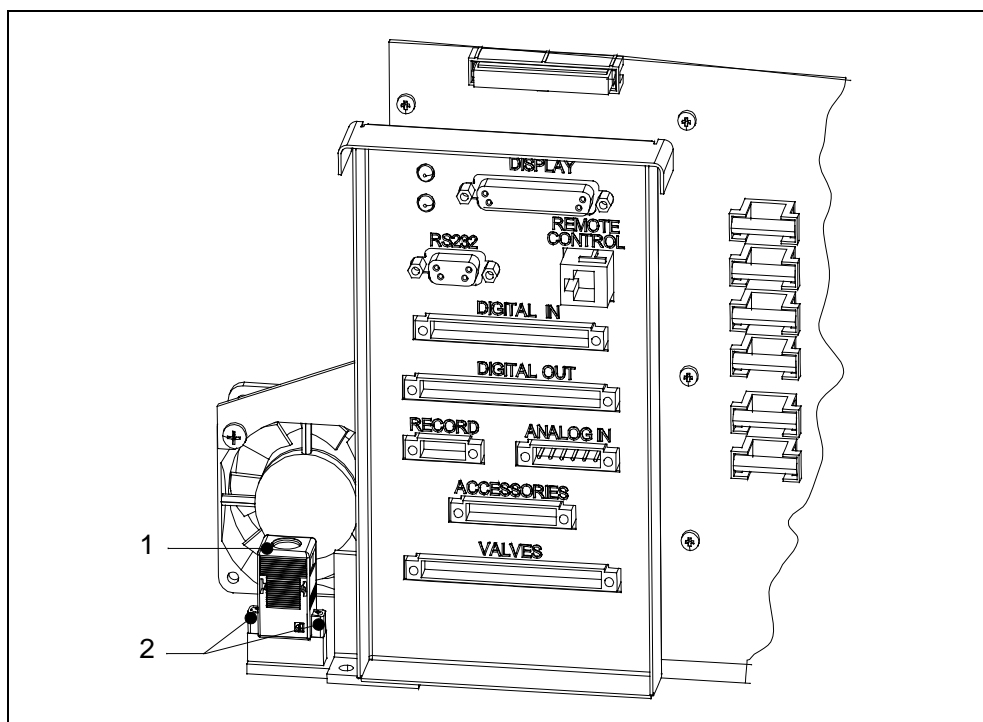

Fig. 7-7 I•STICK replacement

| Item | Description | Item | Description |
|------|-------------|------|---------------|
| 1 | I•STICK | 2 | Fixing screws |

After the screws have been released, pull the I•STICK out of the socket and insert the I•STICK of the defect device.

The installation is performed in reverse order.

7.9 Replace Vent Filter

The flood filter is checked and replaced in the course of the 5000-hours maintenance. In case of extreme operating conditions shorter maintenance times could be reasonable.

Required Tools

- Allen key SW 8

Required material

- Replacement filter (2 pcs.) Order No.: 200 000 683

Access to the flood filter is only possible when the cover of the Modul1000 has been removed. Follow the instructions in [7.5.1 Opening of the Device](#).

Notice: Please observe the safety instructions in this chapter.

- To dismantle the vent filter, disconnect the hose connections of the filter from the quick-connecting couplings. By pressing on the outside ring on the quick connecting couplings, the hose can be pulled off. Please find the mounting positions in the following [Fig. 7-8](#).

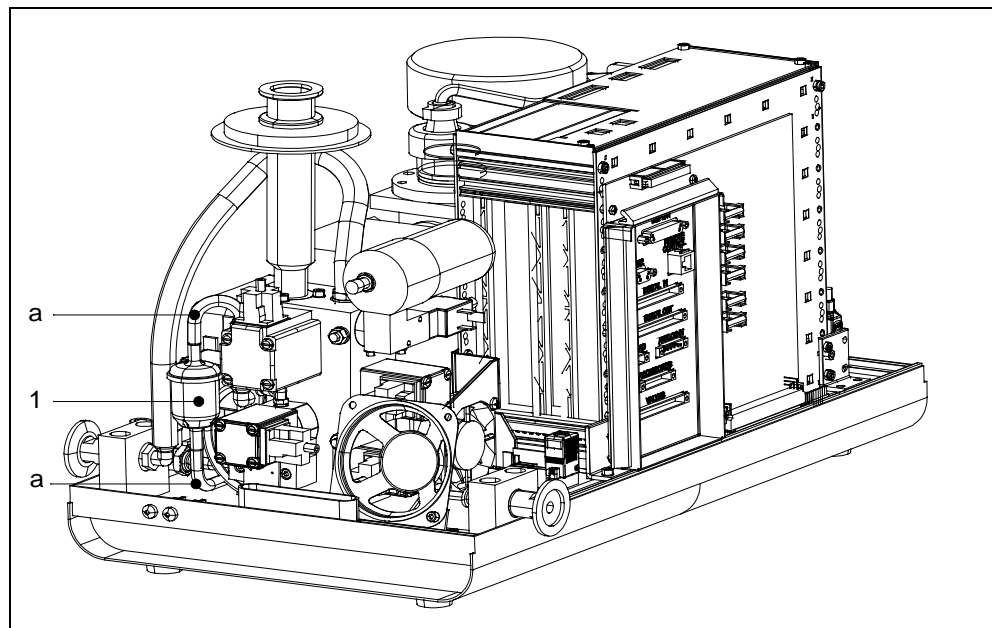



Fig. 7-8 Flood filter replacement in Modul1000

| Item | Description | Item | Description |
|------|-------------|------|--------------|
| 1 | Vent filter | 2 | Hose routing |

8 Transport and disposal



Caution

Risk of damage.

The Modul1000 may be damaged by improper transport conditions.

Always transport the Modul1000 in its original packaging.

8.1 Transporting after Contamination

If equipment is returned to INFICON or an authorized INFICON representative, indicate whether the equipment is free of substances damaging to health or whether it is contaminated. If it is contaminated, also indicate the nature of the hazard. INFICON must return any equipment without a Declaration of Contamination to the sender's address.

You will find an example of the form below. The appropriate form is attached to the Modul1000.

Declaration of Contamination

The service, repair, and/or disposal of vacuum equipment and components will only be carried out if a correctly completed declaration has been submitted. Non-completion will result in delay.
This declaration may only be completed (in block letters) and signed by authorized and qualified staff.

1 Description of product

Type _____
Article Number _____
Serial Number _____

2 Reason for return

3 Operating fluid(s) used (Must be drained before shipping.)

4 Process related contamination of product:

| | | |
|--------------------------|--------------------------------|---------------------------------|
| toxic | no <input type="checkbox"/> 1) | yes <input type="checkbox"/> |
| caustic | no <input type="checkbox"/> 1) | yes <input type="checkbox"/> |
| biological hazard | no <input type="checkbox"/> | yes <input type="checkbox"/> 2) |
| explosive | no <input type="checkbox"/> | yes <input type="checkbox"/> 2) |
| radioactive | no <input type="checkbox"/> | yes <input type="checkbox"/> 2) |
| other harmful substances | no <input type="checkbox"/> 1) | yes <input type="checkbox"/> |



2) Products thus contaminated will not be accepted without written evidence of decontamination!

The product is free of any substances which are damaging to health

yes 1) or not containing any amount of hazardous residues that exceed the permissible exposure limits

5 Harmful substances, gases and/or by-products

Please list all substances, gases, and by-products which the product may have come into contact with:

| Trade/product name | Chemical name (or symbol) | Precautions associated with substance | Action if human contact |
|--------------------|---------------------------|---------------------------------------|-------------------------|
| | | | |
| | | | |
| | | | |

6 Legally binding declaration:

I/we hereby declare that the information on this form is complete and accurate and that I/we will assume any further costs that may arise. The contaminated product will be dispatched in accordance with the applicable regulations.

Organization/company _____ Post code, place _____
Address _____ Phone _____ Fax _____
Phone _____ Email _____
Email _____ Name _____
Name _____

Date and legally binding signature _____ Company stamp _____

This form can be downloaded from our website. Copies: Original for addressee - 1 copy for accompanying documents - 1 copy for file of sender

Fig. 8-1 Sample of form for declaring contamination

Operating Manual

(1011)

jinb80e1-h

Transport and disposal

8-1

8.2 Disposal

When disposing the Modul1000, consider your federal law concerning the disposal of electronic devices.

9 Technical Data

9.1 Technical data of components

9.1.1 Power supply

| | |
|-----------------------------------|-------------------------|
| Mains voltage and frequencies | 100 V...240 V, 50/60 Hz |
| Power consumption | < 400 VA |
| Protective system - basic device | IP20 |
| Protective system - control panel | IP40 |

9.1.2 Weight / dimensions

| | |
|---------------------------------------|--------------------|
| Dimensions (L x W x H) | 535 x 350 x 339 mm |
| Weight | 30 kg |
| Noise level dB(A) | < 70 |
| Noise level dB(A) | < 56 |
| Noise level dB (A) 0.5 m distance | < 56 |
| Audio alarm dB(A) | 90 |
| Contamination level (to IEC 60664-1) | 2 |
| Overvoltage category (to IEC 60664-1) | II |
| Mains connection line | 3 m |

9.1.3 Characteristics

| | |
|--|--------------------------------|
| Max. inlet pressure (Modul1000) | 0.4 mbar |
| Max. inlet pressure (Modul1000b) | 3.0 mbar |
| Minimum detectable Helium leak rates in vacuum mode (ULTRA) | < 5×10^{-12} mbar l/s |
| Minimum detection limit in sniff mode | < 5×10^{-8} mbar l/s |
| Maximum allowed gas flow in the sniffer line | 25 sccm |
| Maximum Helium leak rate which can be displayed | 0.1 mbar l/s |
| Measurement range | 12 decades |
| Maximum pumping speed (helium) at inlet ULTRA mode | 2.5 l/s |
| Time constant of leak rate signal (63% of the final value) | < 1 s |
| Detectable masses | 2, 3 and 4 |
| Run-up time (after starting) | ≤ 3 min. |
| Mass spectrometer | 180° magn. Sector range |
| Ion source (2-cathodes) | Iridium/Yttrium oxide |
| Inlet Port | DN25 KF |
| Valves | solenoid |

9.1.4 Environmental Conditions

| | |
|---|---|
| For use within buildings | |
| Permissible ambient temperature (during operation) | +10° C ... +40° C 50° F ... 104° F |
| Permissible storage temperature | 0° C ... +60° C 32° F ... 140° F |
| Maximum relative humidity | 80% at 31°C / 88°F, linearly decreasing to 50 % at 40 °C / 104 °F |
| Max. permissible height above sea level (during operation) | 2000 m |

9.2 Control via the PLC inputs and outputs

If the Modul100 shall be controlled via the PLC inputs and output, select one of the control location "PLC", "All" or "Local and PLC" (refer to chapter or SB).

9.2.1 PLC inputs



Caution

The electronic system of the Modul1000 may be damaged by too high input voltages.

The maximum permissible input direct voltage is 30V.

The 14-pin Phönix-connector box is located at the back of the device and is marked with PLC In / Audio. The pin assignment of the connector box is freely selectable (Also refer to Interface Description).

| Pin | Assignment | |
|-----|---|------------------------------------|
| 1 | 24V fuse-protected with F3 on the interface board (0.8 A, maximum output current, on this pin together with Pin 1 on connection PRESSURE GAUGE) | |
| 2 | GND | |
| 3 | Freely configurable PLC input | e.g. START (default setting) |
| 4 | Freely configurable PLC input | e.g. STOP (default setting) |
| 5 | Freely configurable PLC input | e.g. ZERO (default setting) |
| 6 | Freely configurable PLC input | e.g. CAL (default setting) |
| 7 | Freely configurable PLC input | e.g. CAL INTERN(default setting) |
| 8 | Freely configurable PLC input | e.g. CAL EXTERN (default setting) |
| 9 | Freely configurable PLC input | e.g. CLEAR (default setting) |
| 10 | Freely configurable PLC input | e.g. GAS BALLAST (default setting) |
| 11 | PLC GND (reference potential) | |
| 12 | free | |
| 13 | AUDIO_OUT | 5V level, PWM-output |
| 14 | GND (24 V) | |

The pins are numbered from the left to the right side.

Error or warning messages may occur when the connection cable is disconnected or connected during operation.

Description of operation mode of the Digital In.

A signal between 0 V and 7 V is recognized to be LOW, a signal >13V is recognized to be HIGH. The maximum signal level of direct voltage is 30V. All functions are also selectable as inverted functions.

Notice: Signals at these inputs are only accepted if the location of control is set to *PLC* or *Local and PLC*.

ZERO

Edge-controlled input

Change from LOW to HIGH: Activate ZERO.

Change from HIGH to LOW: Deactivate ZERO

START/STOP

Edge-controlled input

Change from LOW to HIGH: activate START

Change from HIGH to LOW: activate STOP

START

Edge-controlled input

Change from LOW to HIGH: carry out START

STOP

Edge-controlled input

Change from LOW to HIGH: activate STOP

If this input is HIGH for a longer period than it is set in "Ventilation Delay", ventilate additionally.

VENT

Edge-controlled input

Change from LOW to HIGH: Flooding

GAS BALLAST

Edge-controlled input

Change from LOW to HIGH: Activate Gas Ballast/Purge.

Change from HIGH to LOW: Deactivate Gas Ballast/Purge.

CLEAR

Edge-controlled input

Change from LOW to HIGH: Acknowledge error message or abortion of a calibration.

CAL

Edge-controlled input

Change from LOW to HIGH:

In case the device is in Standby mode: Start internal automatic calibration. In case the machine is in Measurement mode: Start manual calibration. (Precondition: external test leak has to be open and leak rate signal is constant)

Change from HIGH to LOW:

External calibration: approve that external test leak is closed and leak rate signal is stable.

CAL INT

Edge-controlled input

Change from LOW to HIGH: start internal automatic calibration.

CAL EXT

Edge-controlled input

Change from LOW to HIGH: Start external manual calibration.

CYCLE (inverted START / STOP input)

Status-controlled input

Change from LOW to HIGH: In the Standby status, START will be executed and in the Measurement status, STOP will be executed.

GAS BALLAST ON

Edge-controlled input

Change from LOW to HIGH: The gas ballast valve is opened.

GAS BALLAST OFF

Edge-controlled input

Change from LOW to HIGH: The gas ballast valve is closed.

ZERO ON

Edge-controlled input

Change from LOW to HIGH: Activate ZERO

ZERO is switched off, when the devices switches over to Standby.

SNIFF

Status-controlled input

Change from LOW to HIGH in Standby mode:
Switching over to the SNIFF mode.

Change from HIGH to LOW in Standby mode:
Switching over to the set operating mode.

9.2.2 PLC Outputs

The 16-pin Phönix-connector box is located at the back of the device and is marked with PLC Out. The pin assignment of the connector box is freely selectable.

Notice: Relay outputs (pin 3-12): Maximum load 60V DC / 25V AC / 1A ohmic load, for maximum 500,000 switching operations.

Semiconductor-relay outputs (pin 13, 14): maximum load 30 V, 1 A for frequent switching operations.

For frequent switching operations (more than 500,000 within the planned operating time), only the semiconductor-relay outputs should be used.

| Pin | Assignment | |
|-----|---|------------------------------------|
| 1 | 24V fuse-protected with F4 on the interface board (1.6A, maximum output current, on this pin together with pin 1 on pin VALVES) | |
| 2 | GND | |
| 3 | Normally-open contact to pin 15 | e.g. TRIGGER1 (default setting) |
| 4 | Normally-open contact to pin 15 | e.g. TRIGGER2 (default setting) |
| 5 | Normally-open contact to pin 15 | e.g. TRIGGER3 (default setting) |
| 6 | Normally-open contact to pin 15 | e.g. ZERO ACTIVE (default setting) |
| 7 | Normally-open contact to pin 15 | e.g. EMISSION ON (default setting) |
| 8 | Normally-open contact to pin 15 | e.g. ERROR (default setting) |
| 9 | Normally-open contact to pin 15 | e.g. CAL ACTIVE (default setting) |
| 10 | Normally-open contact to pin 15 | e.g. CAL REQUEST (default setting) |
| 11 | Normally-open contact to pin 15 | e.g. OPEN (default setting) |
| 12 | Normally-open contact to pin 15 | e.g. OPEN (default setting) |
| 13 | Normally-open contact to pin 15 | e.g. OPEN (default setting) |
| 14 | Normally-open contact to pin 15 | e.g. OPEN (default setting) |
| 15 | „COM_DIGOUT“ common reference potential for all outputs | |
| 16 | Not used | |

All functions are also selectable as inverted functions. All relay outputs are open when the device has been switched off.

OPEN:

If not triggered, the relay contact is open.

CLOSE:

If not triggered, the relay contact is closed.

TRIGGER 1, 2, 3

Closed, when the lower trigger level has not been reached and the device is in Measurement mode.

ZERO ACTIVE

Closed when the ZERO-function has been switched on.

READY

Closed, when the device is ready for measurement (Emission ON, no error).

STANDBY

Closed, when the device is in STANDBY mode.

MEASURE

Closed, in case the device is in Measurement mode.

VENTED

Closed, when the inlet is ventilated.

ERROR

Closed, when no error occurs.

Open, when an error occurs.

WARNING

Closed, when no warning occurs.

Open, when a warning appears.

CAL ACTIVE

Closed, when a calibration routine is run.

CAL REQUEST

External, manual calibration active:

Open if the external test leak has to be closed.

External, manual calibration not active:

Open, when a calibration request is still active.

REC STROBE

Open, when the recorder output value becomes invalid during the change of the decade. Only used when the recorder output is set on „leak rate“.

GAS BALLAST

Closed, when the Gas Ballast function is used.

EMISSION ON

Closed when emission has been switched on.

CYCLE ACTIVE

Closed when the device is in evacuation, measuring or calibration mode.

PUMP DOWN

Closed when the device is in evacuation mode.

SNIFF

Closed, when the device is in SNIFF mode.

This output has a feedback function for the PLC input "SNIFF".

9.3 The digital valve outputs

The 16-pin Phönix-connector box is at the back of the device and marked with "VALVES".

This connector box is used to control external valves.

They can be divided in 2 groups:

- 1 The pins 13, 14 and 15 are for the connection of a 24 V-valve; maximum withdrawable current per output 1A. Their common reference point is pin 16 (GND).
- 2 8 valves can be connected to the contacts 5 to 12. To be more flexible, these switched outputs are designed to be floating: the user can connect an external direct voltage source. It must safely be separated from the power supply network and may apply maximum 30 V.

The 24V-power supply unit of the Modul1000 can be used for supplying the valves. The valve switches connect to the 24 V-power supply unit on pin 3. Each valve switch may be loaded with maximum 0.2 A.

Via this pin, the following valves can be controlled by the Modul1000.

| Pin | Assignment |
|-----|---|
| 1 | 24V fuse-protected with F4 (1.6 A) on the interface board. The sum of the maximum supplied current to this pin and the received current from pin 1 on the outputs PLC OUT and ACCESSORIES has to be lower than 1.6 A. |
| 2 | GND |
| 3 | Supply voltage external (24V / 30V max.) |
| 4 | Not used - can be used as support pin for the external wiring. |
| 5 | Output 1 (V30 Commander mode -evacuate test sample) |
| 6 | Output 2 (V31 Commander mode - flood test sample) |
| 7 | Output 3 (V32 Commander mode - valve empty test sample) |
| 8 | Output 4 (V33 Commander mode - valve fill test sample) |
| 9 | Output 5 (V34 Commander mode Emergency valve) |
| 10 | Output 6 (V35) |
| 11 | Output 7 (V36) |
| 12 | Output 8 (V37 external test leak valve 24V / <0,2A) |
| 13 | Output 9 (V20 partial flow valve, 24V / <1A) *) |
| 14 | Output 10 (V21 Flooding valve, 24V / <1A) *) |
| 15 | Output 11 (V22 Gas ballast valve, 24V / <1A) *) |
| 16 | GND |

*) If control inputs are connected (e.g. valves with integrated electronic circuitry) instead of solenoid valves, a resistance of 10 kOhm \pm 5 % (0.5 W) has to be shunted.

9.4 Analogue Output

The 4-pin Phönix-connector box is located at the back of the device and is marked with "RECORDER".

The analogue recorder outputs may be used to log the leak rate, the inlet pressure and the fore-vacuum pressure. The recorder output values are updated every 50 ms. Both recorder outputs can be set individually for the output of leak rates and pressures. The measured values are provided as an analogue signal in the range of 0 V ... 10 V. The resolution is limited to 10 mV. The instrument which is connected to the recorder output (e. g. an X(t) recorder) should have an input resistance of > 2.5 kOhm. The test voltages are applied to pins 1 and 4. The reference potential (GND) is connected to the pins 2 and 3. The pins are numbered consecutively from the left to the right side.

Accuracy of the plotter outputs:

± 50mV offset plus

± 1% from the measured value (current output voltage) as linearity deviation (at 25°C)

Notice: The chart recorder outputs are electrically isolated from other plugs. If, in spite of this, hum interference occurs, we recommend supplying the Modul1000 and the recorder by the same mains phase. If this is not possible, you must make sure that the frame ground of both instruments is kept at the same potential.

| Pin | Assignment |
|-----|---------------------------|
| 1 | Analog 1 |
| 2 | GND (reference potential) |
| 3 | GND (reference potential) |
| 4 | Analog 2 |

9.4.1 Configuration of the analogue outputs

Various types of presentations are provided for displaying the measured values (assignments) for the analogue output. The different assignments can be selected via the optional control unit.

OFF

The recorder output is switched off.

p1 (inlet pressure) / p2 (fore-vacuum pressure)

The output voltage of the pressure gauges for the Inlet pressure p1 or the fore-vacuum pressure p2 is displayed.

The leak rate is recorded on a logarithmic scale.

The signals p1 and p2 behave like the characteristics of the TPR265.

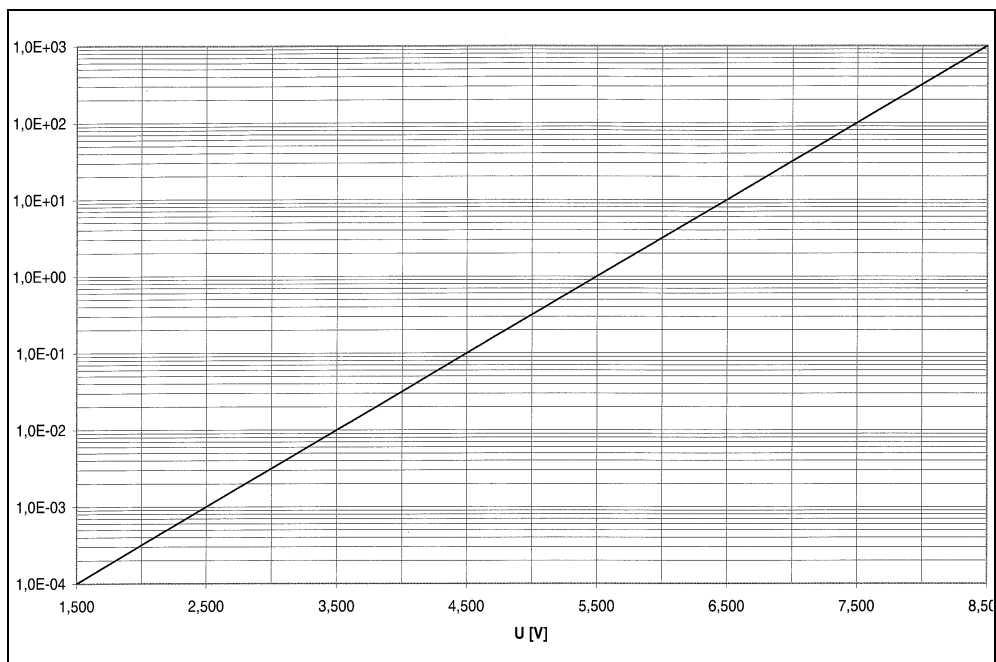

Fig. 9-1 TPR-characteristics (P1, P2; Recorder Output)

p1 (Inlet pressure) / p2 (Fore-vacuum pressure) UL200

The inlet pressure p1 or the fore-vacuum pressure p2 is displayed. This assignment refers to the logarithmic recorder output of the leak detector UL200.

Pressure logarithmic:

U = 1 to 10 V; 0.5 V/decade starting with

1 V = 1·10⁻³ mbar / 1·10⁻³ Pa

LR lin

The leak rate output voltage is linearly scaled. The output voltage is 0 - 10V. The upper limit (refers to 10 V) and the scale division (in Volt/decade) is set via the optional control unit in "Scale recorder output".

LR log

The leak rate output is logarithmically scaled. The output voltage is 1 ... 10 V in optional steps from 0.5 to 10 volts per decade. The scale (in volts/decades) is set via the optional control unit in "Scale recorder output".

Example for signal LR log:

The upper limit value is set to 10⁻⁵ mbar/s (= 10 V)

Scale division is set to 5 V/decade.

The lower limit is at 10⁻³ mbar/s (= 0 V)

LR mantissa:

The leak rate mantissa is linearly displayed from 1...10V.

LR exponent

The leak rate exponent is displayed as step function:

U = 1...10 V with steps of 0.5 V per decade, starting with 1 V = 1×10^{-12} .

LR log. H. **$LR = 10(V-E) * 10^{-(11-E)}$**

LR = leak rate

V = output voltage

E = output voltage values rounded-up (1V, 2V, 3V, 4V, ...)

Voltages between 1 V to 1.1 V, 2 V to 2.1 V, 3 V to 3.1 V etc. are not displayed.

9.5 Pin Assignments

9.5.1 PLC IN / AUDIO

All inputs are electrically isolated by opto-couplers.

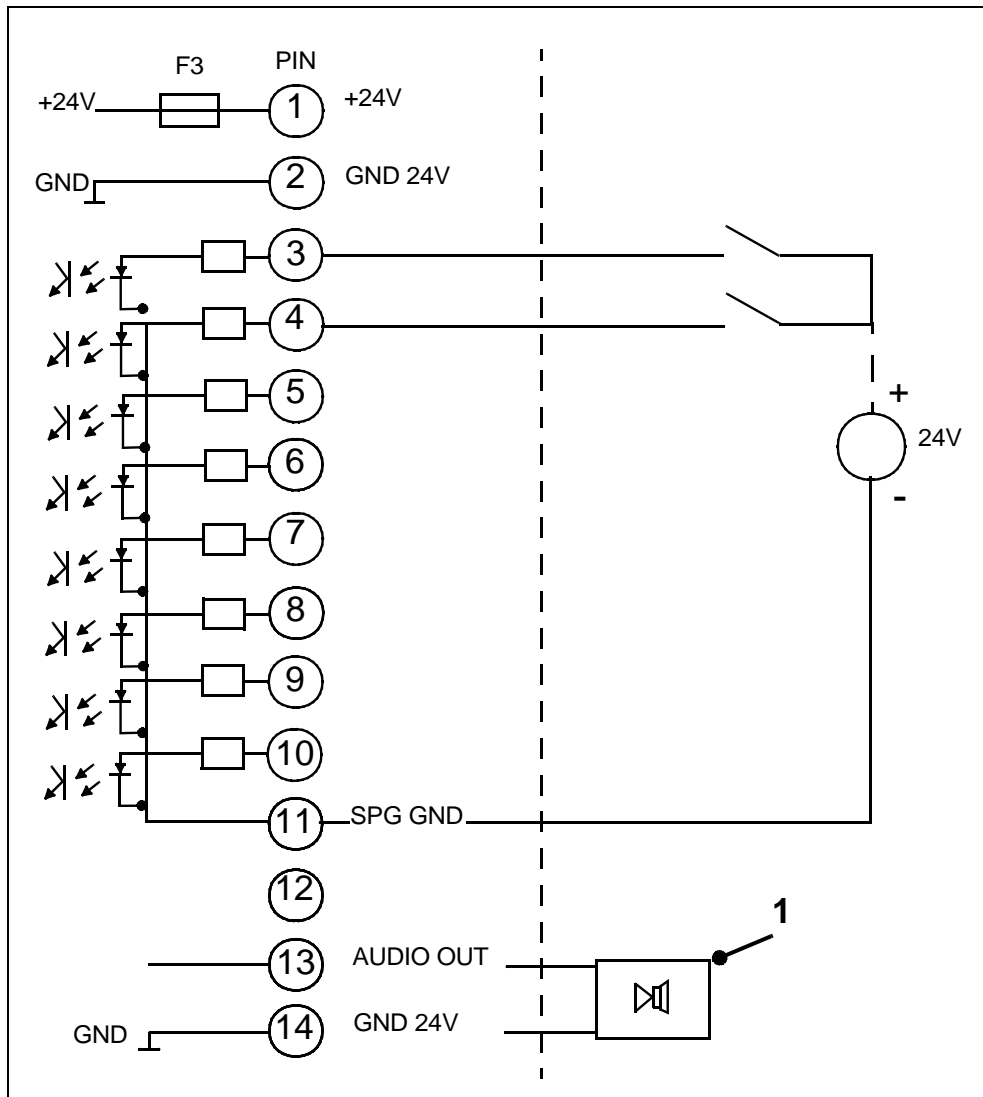

Fig. 9-2 External circuitry, e.g. PLC with external voltage supply unit.

| Item | Description |
|------|------------------------------|
| 1 | External, active loudspeaker |

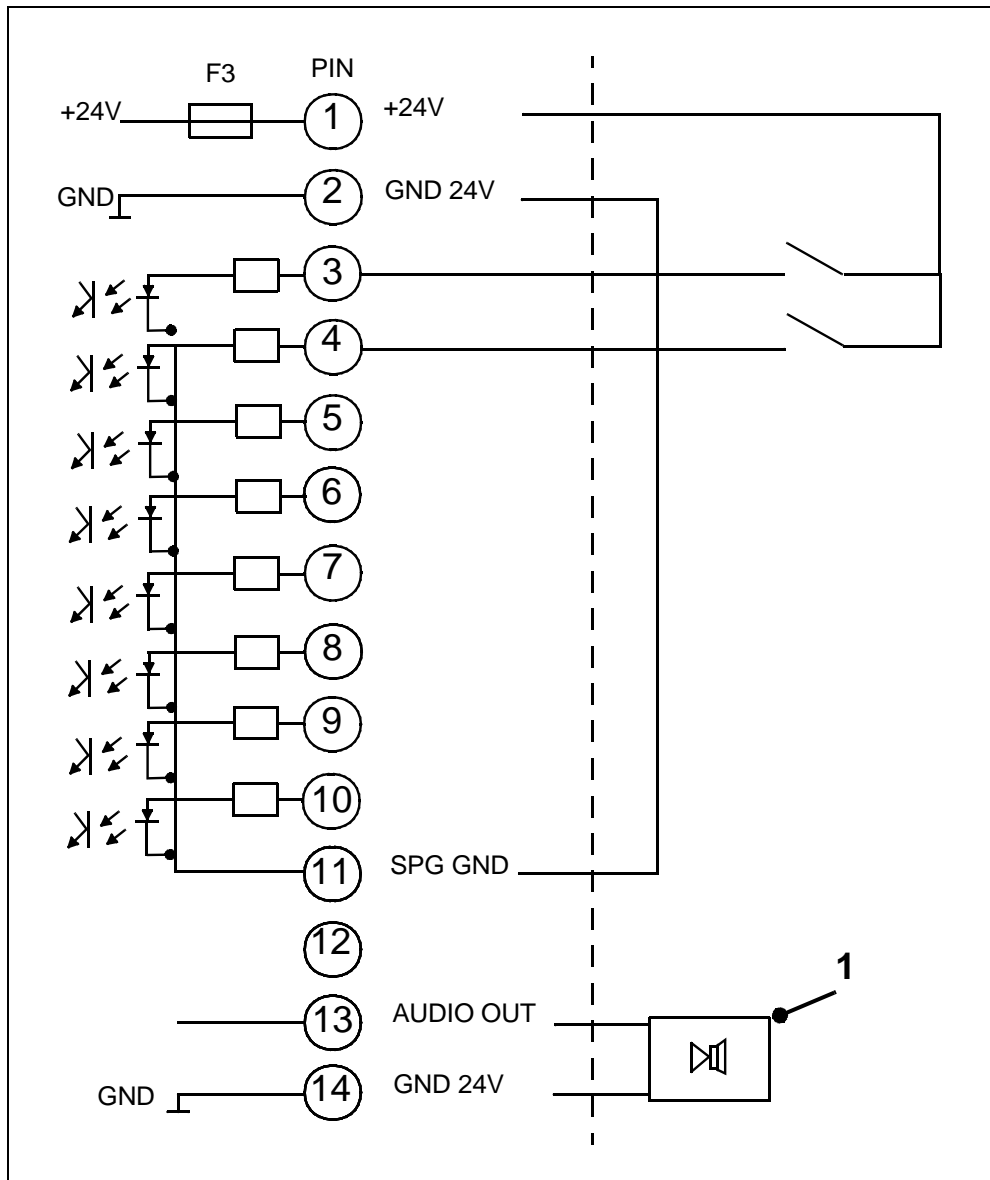

Fig. 9-3 External circuitry, e.g. PLC with internal voltage supply unit.

9.5.2 PLC OUT

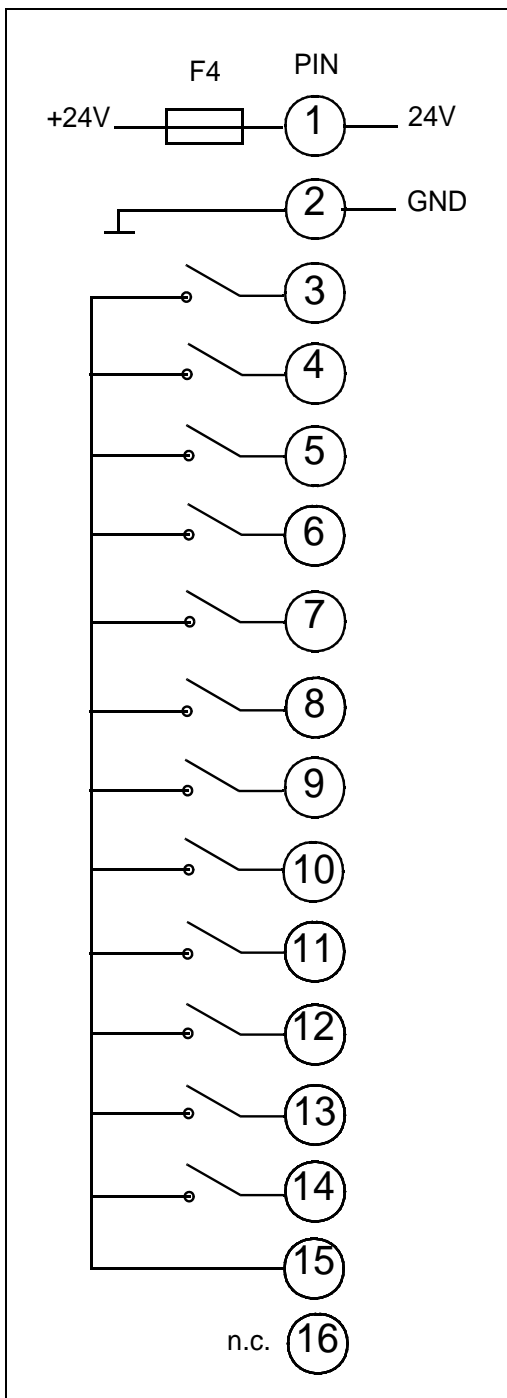

Fig. 9-4 PLC OUT

PIN 3 - 12: Relay contacts, max. 60 V DC / 25 V AC / 1 A

PIN 13, 14: Semiconductor relays, max. 30V DC / 1 A

9.5.3 Pressure Gauge

Connection of sensors with 4 ... 20 mA signal

Notice: Arrange the jumpers on the interface boards accordingly.

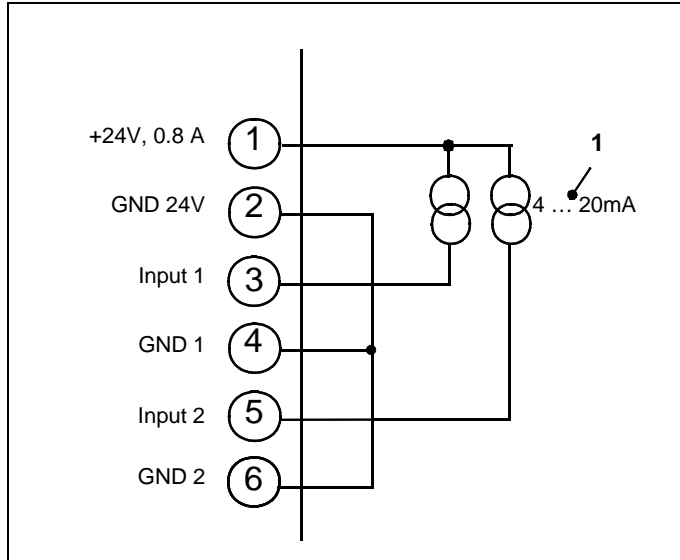

Fig. 9-5 Internal power supply +24 V

| Item | Description |
|------|------------------|
| 1 | Pressure sensors |

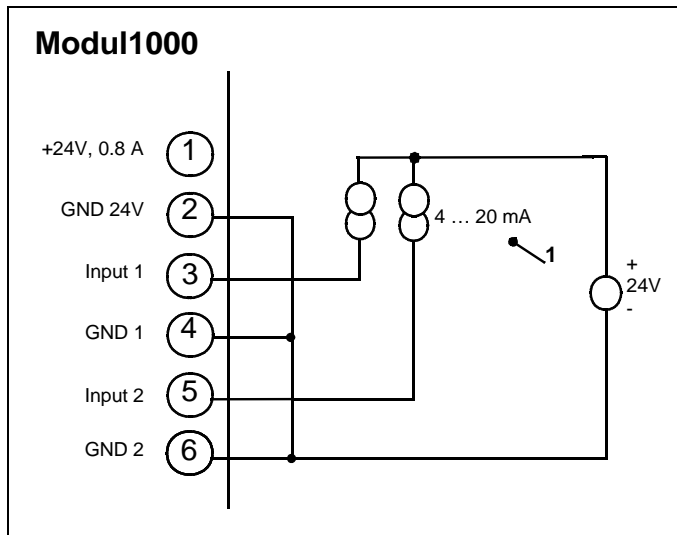

Fig. 9-6 External supply voltage 24V with common GND

| Item | Description |
|------|------------------|
| 1 | Pressure sensors |

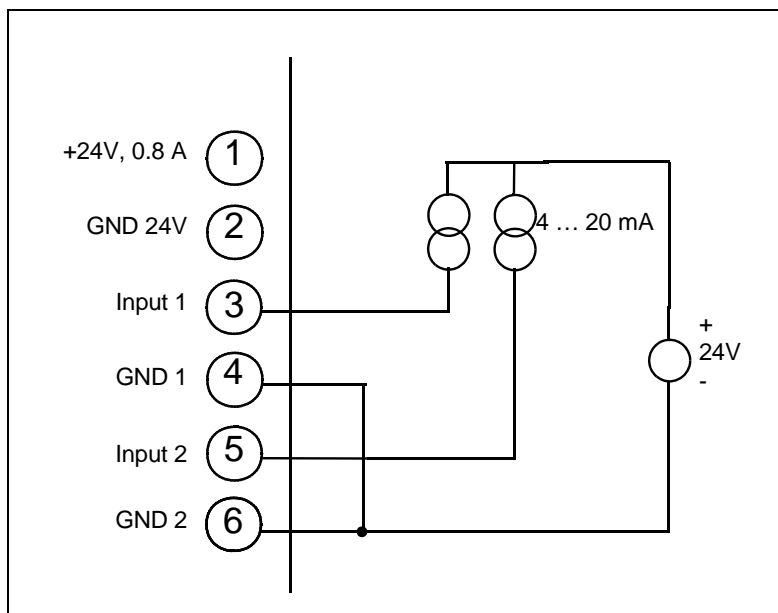

Fig. 9-7 External sensor supply 24 V with electrically isolated installation of mass

The voltage difference between pin 2 and the pins 4 and 5 is maximum ± 4 V.

Connection of sensors with
0 ... 10V signal

Notice: Arrange the jumpers on the interface boards accordingly.

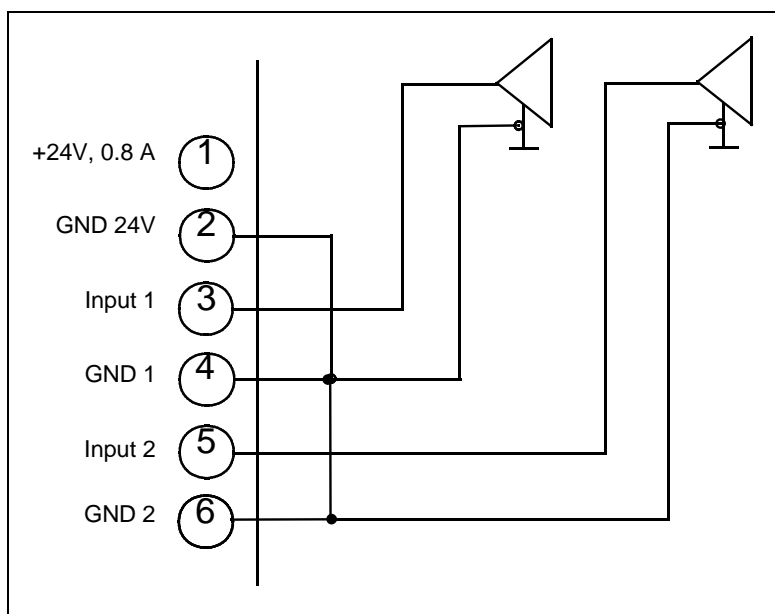

Fig. 9-8 Connection with common mass

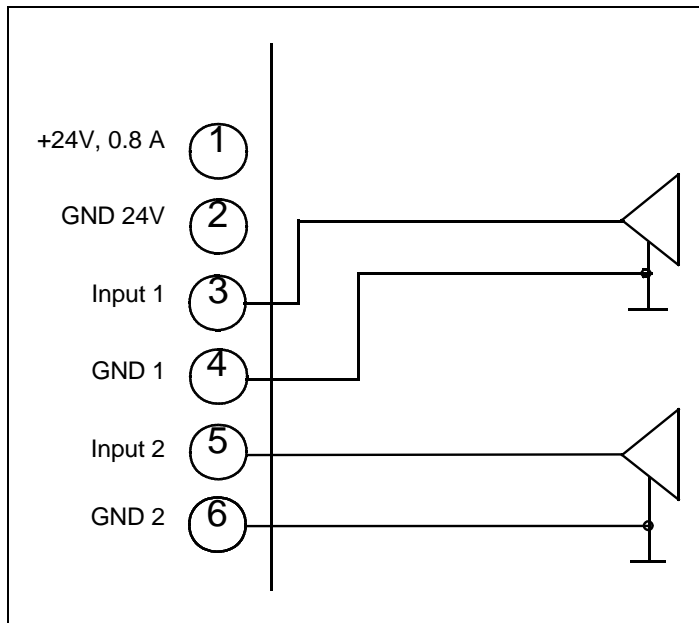

Fig. 9-9 Connection with separated mass arrangement

The voltage difference between pin 2 and the pins 4/6 may be maximum ± 4 V.

9.5.4 Valves

Internal power supply

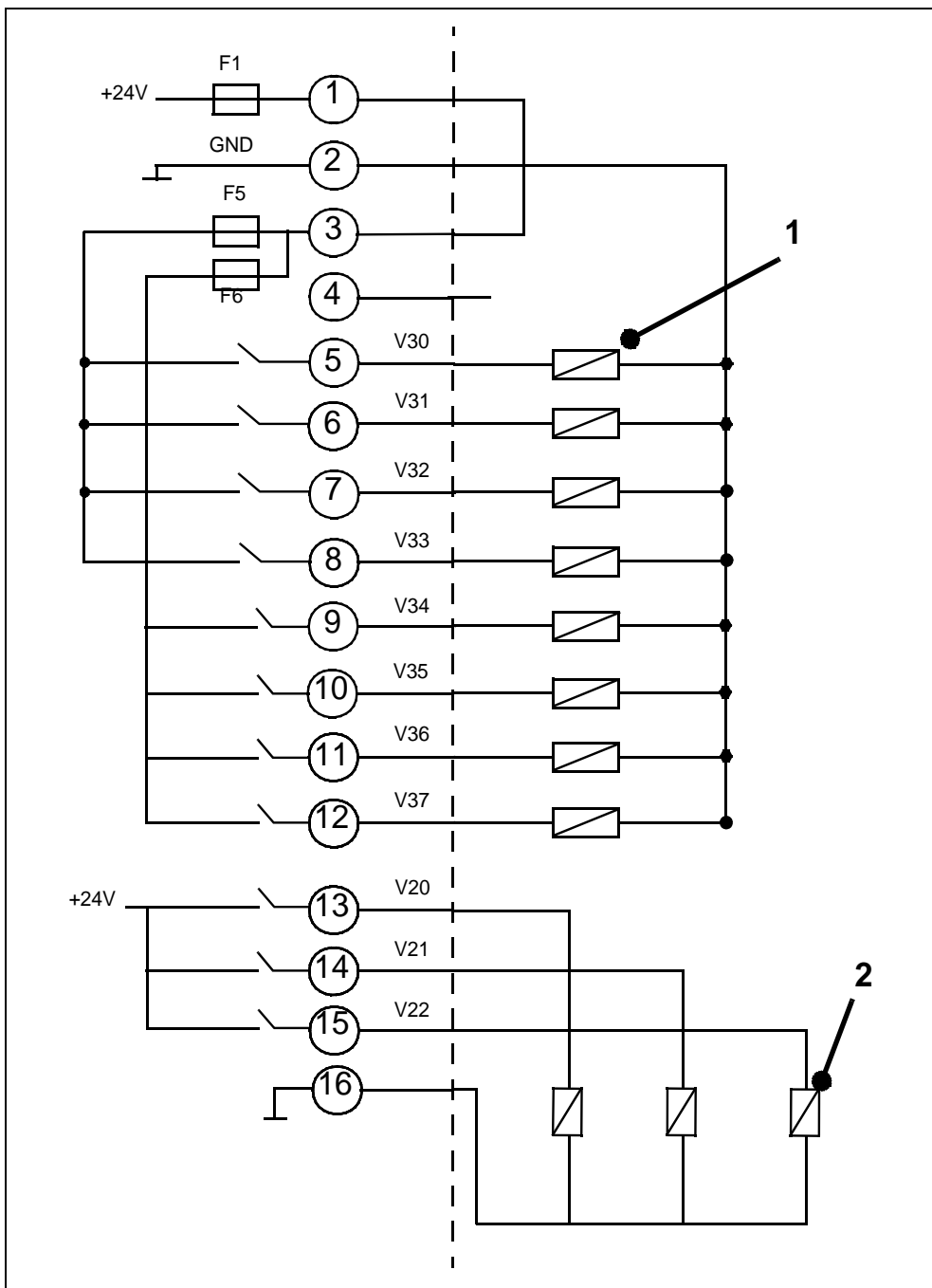

Fig. 9-10 Connection example

| Item | Description |
|------|-------------------------------------|
| 1 | Valves I max < 0.2 A, maximum 8 pcs |
| 2 | Valves I max < 1A |

Operating Manual

(1011)

jnb80e1-h

External power supply

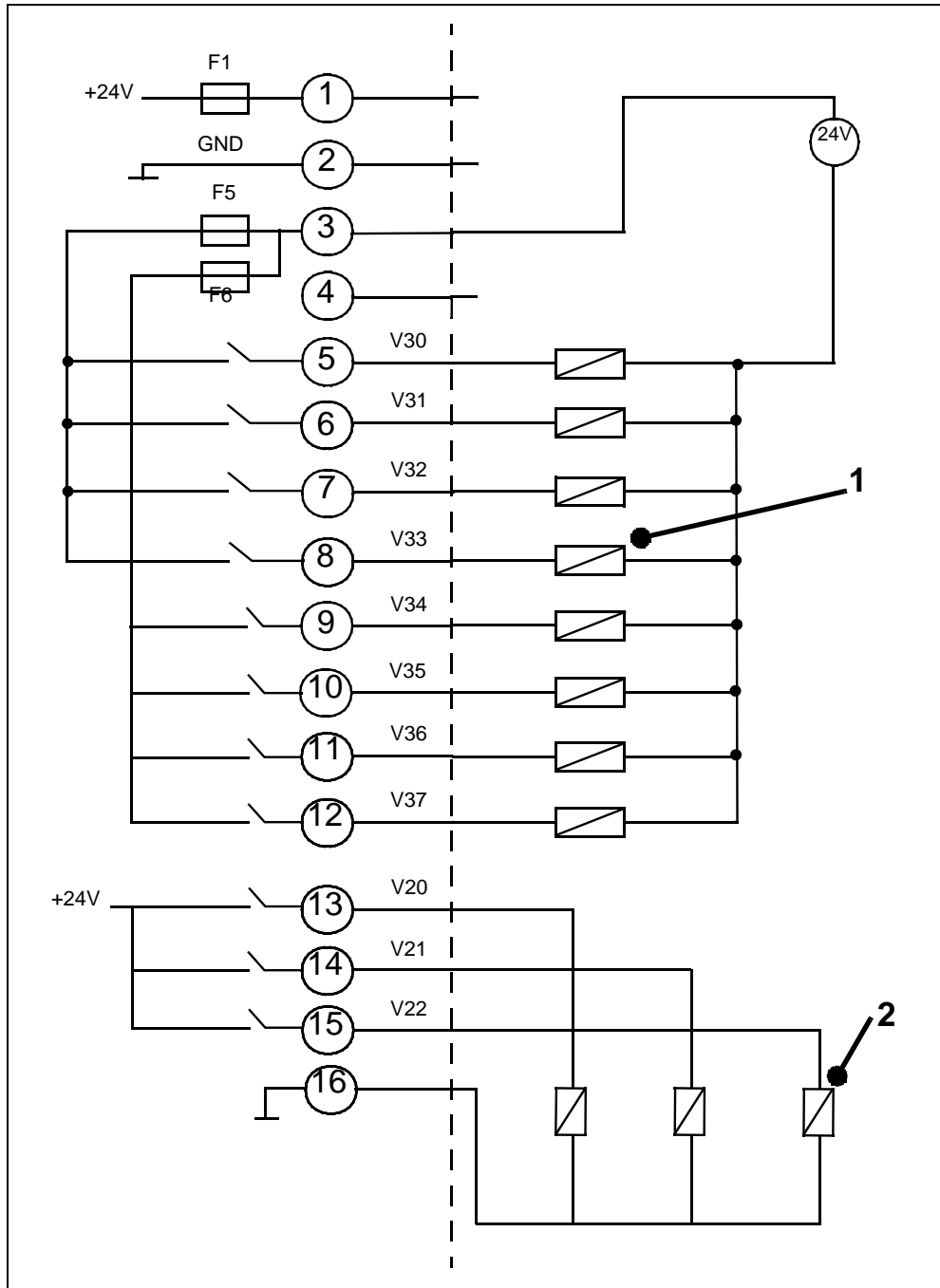

Fig. 9-11 Connection example

| Item | Description |
|------|-------------------------------------|
| 1 | Valves I max < 0.2 A, maximum 8 pcs |
| 2 | Valves I max < 1A |

9.5.5 Recorder

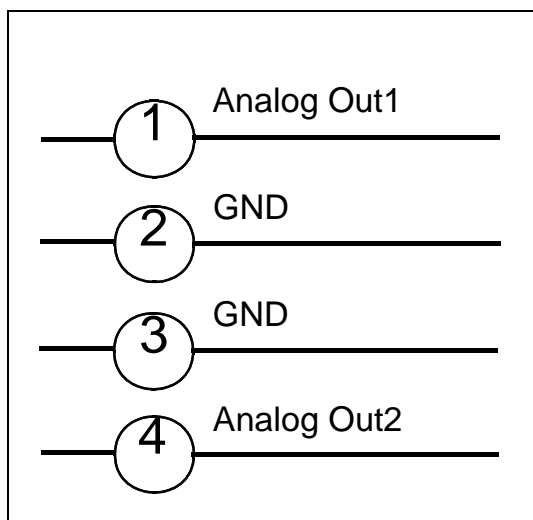

Fig. 9-12

Load resistance $>10\text{k}\Omega$

Accuracy of the analogue output:

Final value: 10V: 1.2% of the final value

Offset $\pm 1\%$ of the final value

9.6 Installation diagram of the control unit for rackinstallation

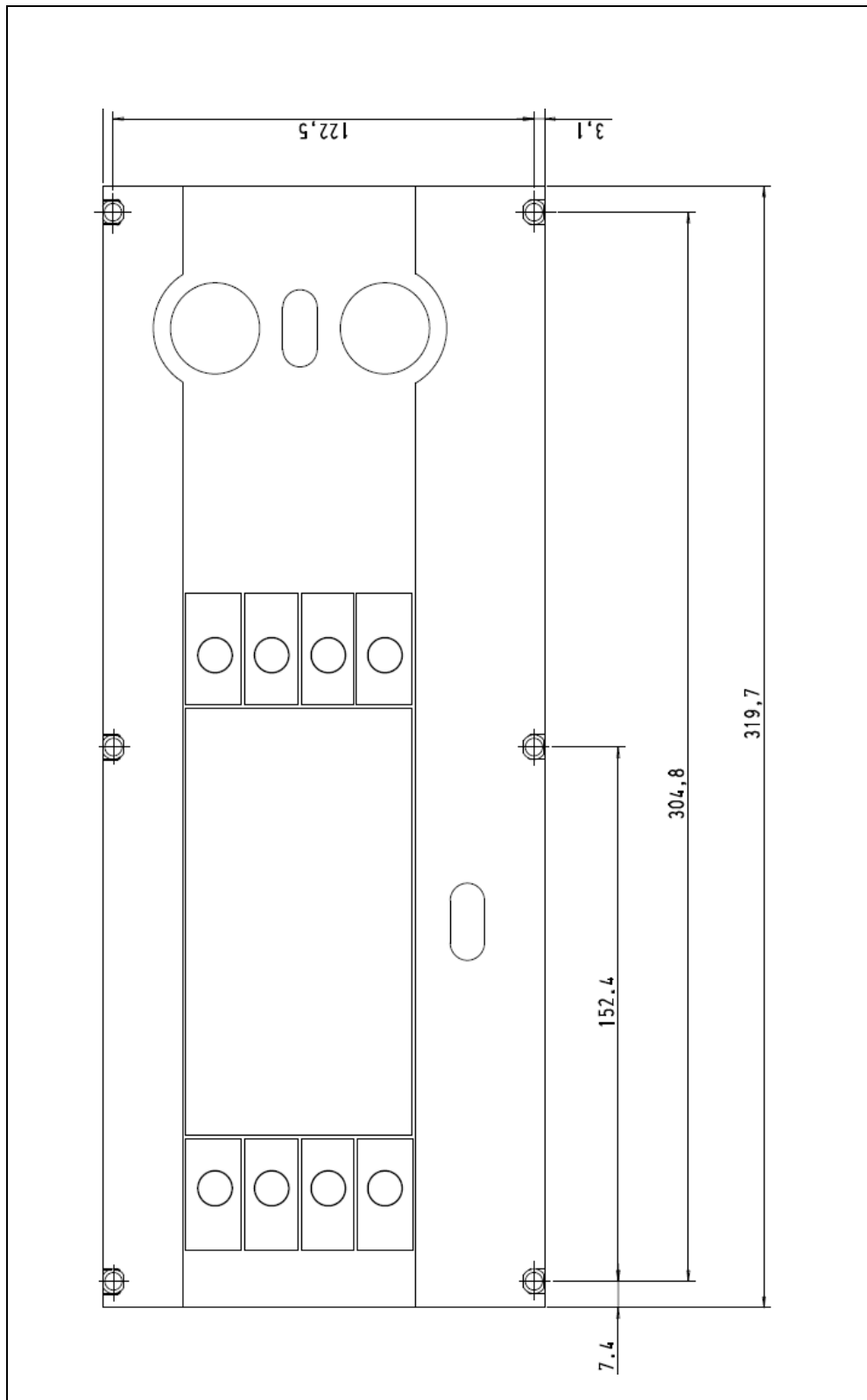

Fig. 9-13 Cut-out of the switch cabinet for the installation of the control unit

9.7 Commander mode

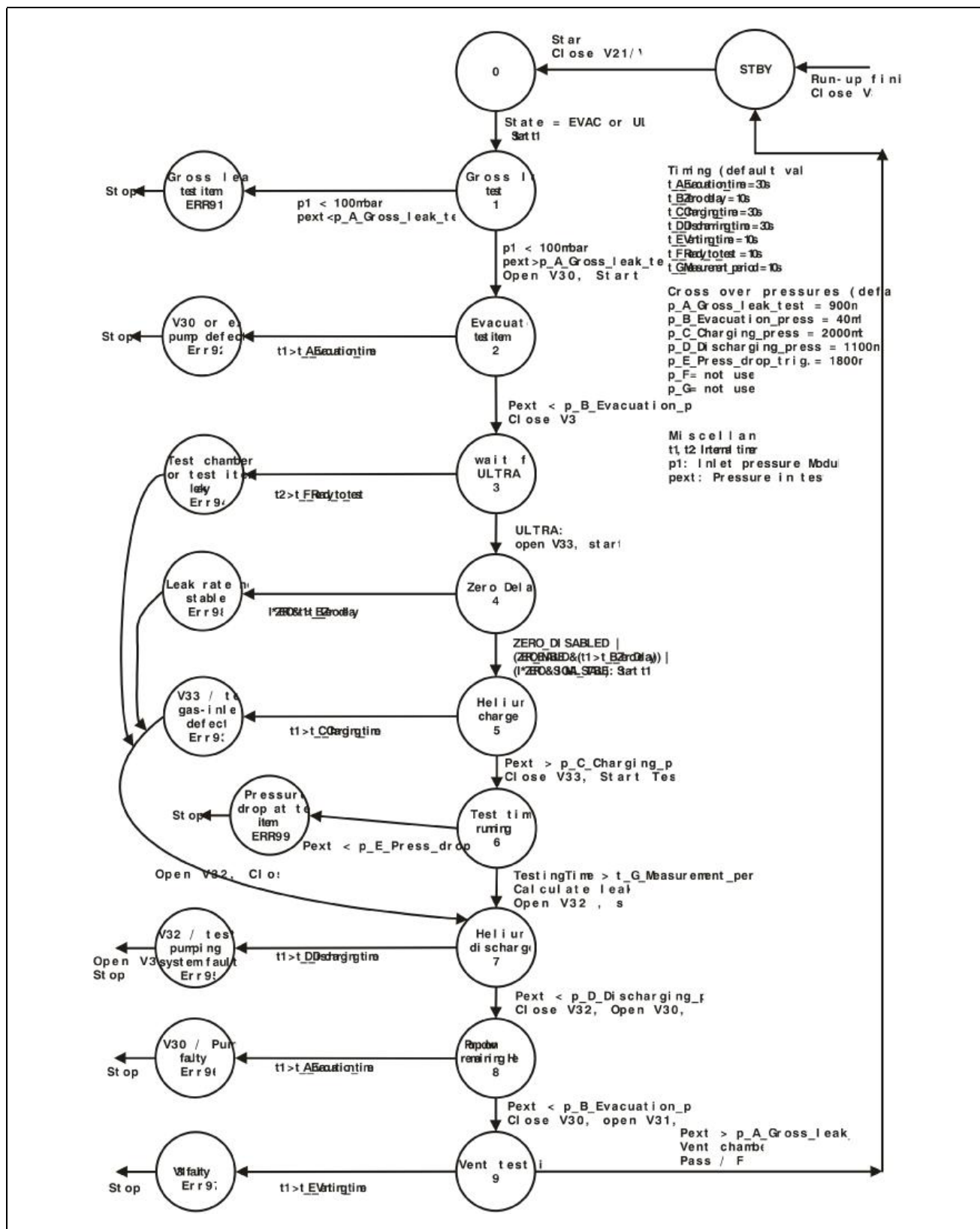



Fig. 9-14 Flow Chart

Operating Manual

(1011)

jnb80e1-h

9.8 CE-Certificate



EC-Declaration of Incorporation

We - INFICON GmbH - herewith declare that the products defined below meet the basic requirements regarding safety and health of the relevant EC directives for partly completed machinery by design, type and the versions which are brought in to circulation by us.

In case of any product changes made without our approval, this declaration will be void.

The products meet the essential requirements of the following directives

- **Directive on Low Voltage (2006/95/EC)**
- **Directive on Electromagnetic Compatibility (2004/108/EC)**
- **Directive on Machinery (2006/42/EC)** according to annex I, Essential health and safety requirements

Designation of the product
Modular Leak Detektor

Model: **Modul 1000**

Catalogue numbers:
550-300
550-310

Applied harmonized standards:

- **EN 61010 - 1 : 2001**
- **EN 61000-6-4 : 2002 Teil EN 55011 Class A**
- **EN 61000-6-3 : 2002 Teil EN 61000-3-2**
- **EN 61000-6-2 : 2000 Teile EN 61000-4-2**
EN 61000-4-3
EN 61000-4-4
EN 61000-4-5
EN 61000-4-6
EN 61000-4-11
- **DIN EN ISO 12100-1 / DIN EN ISO 12100-2**

The partly completed machinery must not be put into service until the final machinery into which it is to be incorporated has been declared in conformity with the provisions of this Directive (2006/42/EC), where appropriate.

The manufacturer undertakes to transmit electronically, in response to a reasoned request by the national authorities, relevant information on the partly completed machinery.
 The relevant technical documentation is compiled in accordance with part B of Annex VII.
 Authorised person for documentation: Hans-Gerd Finke, INFICON GmbH.

Cologne, December 15, 2009 Cologne, December 15, 2009

 Df. Döbler, Manager

 Finke, Research and Development

modul1000.15.12.2009.engl.doc

INFICON GmbH
 Bonner Strasse 498 (Bayenthal)
 D-50968 Köln
 Tel.: (0221) 3474-0
 Fax: (0221) 3474-1429

Fig. 9-15

10 Error Messages and Warnings

| No. | Displayed Message | Description and possible solutions |
|-----|---|--|
| E04 | TMP temperature control defective (E025) | Short circuit in temperature sensor |
| E05 | TMP temperature sensor defective (E026) | Temperature sensor interrupted |
| E06 | TMP frequency too high | Excess speed rate TMP Replace TMP incl. TC 600. Contact INFICON Service. |
| E07 | TMP power supply unit defective. | Power supply output voltage of the TC 600 too low. 24 V-powOperating Manualjinb80e1-her supply unit of Modul1000 - check output voltage Replace TMP incl. TC 600. |
| E08 | TMP starting time error | After 15 minutes warm-up time, the speed of the TMP is lower than 1200 Hz. Fore-vacuum pressure too high Vacuum system is leaking Bearing of turbo molecular pump defective |
| E09 | TMP-connection TC600 - TMP defective | Internal connection TC 600 to TMH 071 defective Replace TMP incl. TC 600. |
| E10 | TMP controller in TC 600 defective | Controller of TC 600 defective Reset the controller with stopped pump (0Hz) using the power switch „ON/OFF“ of the leak detector. Replace TMH incl.TC 600 |
| E11 | TMP wrong pump resistance characteristics | Controller detects wrong pump resistance characteristics Replace TMH incl.TC 600 Contact INFICON Service |
| E12 | TMP motor control defective | Defect in motor output stage or motor control unit Replace TMH incl.TC 600 Contact INFICON Service |
| W13 | TMP unknown TMP-error | Error message from TC 600, for which there is error code specified in the software of the leak detector. The error code of the TC 600 converter is displayed. |
| W15 | Leak rate is too high! Machine was switched to Stand-by mode to prevent HE-contamination! | The survey function „contamination“ is activated. A leak rate higher than the adjusted value was detected. Gross leak. Switch off limit is set too low Alarm delay time too short |
| W16 | Service interval of leak detector has expired! | Service interval of the leak test device has expired. Carry out and acknowledge the service for the leak test device. |
| W17 | Service interval of leak detector has expired! | The service interval for the turbo molecular pump has expired! Period since the service > 2 years Replace the lubricant reservoir of the turbo molecular pump and acknowledge. |

| No. | Displayed Message | Description and possible solutions |
|-----|--|---|
| W18 | Service interval of fan filter has expired! | The service interval for the fan filter chassis has expired! Replace the fan filter and acknowledge the service. |
| W21 | EEPROM time-out for write instruction | Write instruction from the MC68 to the EEPROM was not acknowledged. E-EPROM defective. Defect in cross wiring MC 68 is defective |
| W22 | Overflow of EEPROM parameter queue | Software problem. Please contact the INFICON Service! |
| E23 | External supply voltage (24 V) too high | Voltage monitoring input AD24 A/B > 11.5 V. External power supply on one of the 24 V outputs of the terminal connector of the interface board. |
| E24 | External supply voltage (24 V) too low | Voltage monitoring input AD 24 A/B < 2.5 V. Check the fuses F1 to F4 on the interface board. At least 2 fuses failed. |
| E25 | Reduced valve voltage too low (<7 V) | Reduced valve voltage on E/A board (<7V) E/A board is defective. MC 68 control board is defective.. |
| E26 | Monitoring voltage F3, F4 | Voltage monitoring for fuses F3, F4 AD 24 A < 5,6 V. Fuse F3 interface board (SSK) defective. |
| E27 | Monitoring voltage F3, F4 | Voltage monitoring for fuses F3, F4 AD 24 A < 7.8 V. Fuse F4 interface board (SSK) defective. |
| W28 | Real time clock has been reset! Please enter date and time! | Real time clock has been reset! Battery at MC68 is discharged or faulty. MC68 has been replaced. |
| E29 | 24V supply for fans is defective. | Power supply unit for fans is defective < 20 V. Fuse F11 on wiring backplane has blown. Fan polarity has been interchanged. |
| W31 | The offset voltage of the pre-amplifier is too high. (>5 mV) | Offset voltage of pre-amplifier without emission > 5 mV. The pre-amplifier is faulty. Defective voltage supply of pre-amplifier. Defective MC 68 control board. |
| W32 | Pre-amplifier temperature is too high. (>60°C) | The temperature of the ambience is too high. Heat accumulation due to unfavourable placement of the module. Air filter dirty and have to be changed. The temperature sensor in the pre-amplifier is defective. Defective MC 68 control board. |
| W33 | Pre-amplifier temperatre is too low. (<2°C) | Ambient temperature is too high. The temperature sensor in the pre-amplifier is defective. Defective MC 68 control board. |

| No. | Displayed Message | Description and possible solutions |
|-----|--|---|
| E34 | 24 V voltage at MSV board is too low! | Signal MVPZN on the MSV board is active. 24 V voltage on the MSV board is too low, $U < 18.3$ V. Fuse F1 on the MSV board has burned through. Reference voltage UREF on the MSV board XT7/1 is too high, $U > 5$ V. DC/DC transformer of MSV board is defective 24 V current supply from the main power supply unit is excessively strained or defective. |
| E35 | Anode - cathode voltage is too high! | Anode-cathode voltage is higher than $U > 130$ V. MSV is faulty. |
| E36 | Anode - cathode voltage is too low! | Anode-cathode voltage is lower than $U < 30$ V. Fuse F4 on the MSV board is defective. MSV is faulty. |
| E37 | Reference size of suppressor voltage is too great. | Signal MFSZH on MSV board is active. Suppressor signal control input is too high. Suppressor voltage is short circuited (cable, ion accumulator) MSV is faulty. |
| E38 | Suppressor potential is too high. | Suppressor potential is greater than 363V. MSV is defective. |
| E39 | Suppressor potential is too low. | Suppressor potential is lower than $U < 297$ V. Short circuit in suppressor line. MSV is faulty. High-impedance short circuit in the ion collector. |
| E40 | The anode potential exceeds the target value by more than 10%. | The actual anode potential exceeds its nominal value by 10%. The nominal value can be displayed in the service menu (in "Info") MSV is faulty. MC 68 is defective |
| E41 | The anode potential falls below the target value by more than 10%. | The actual anode potential has dropped below its nominal value by 10%. The nominal value can be displayed in the service menu (in "Info") Brief pressure increase in the mass spectrometer. MSV is faulty. MC 68 is defective |
| E42 | Target value of the anode potential is too high. | Signal MFAZH on MSV board is active. Reference size of the anode potential is too great. Brief pressure increase in the mass spectrometer. Valve contamination causes briefly a high mass spectrometer pressure. Anode voltage has been short circuited. Nominal value of the anode voltage is too high. Anode voltage is limited to about 1,200 V. |
| E43 | Cathode current is too high. | Signal MPKZH on MSV board is active. Cathode current is too high, $I > 3.6$ A. MSV board is defective. |

| No. | Displayed Message | Description and possible solutions |
|-----|--|---|
| E44 | Cathode current is too low! | Signal MPKZN on MSV board is active. Cathode current is too low, $I < 0.2 \text{ A}$. MSV board is defective. Defective ion source plug or cable. |
| W45 | Emission for cathode 1 can not be switched on. | Signal MSIBE on MSV board is not active. Emission of cathode 1 cannot be switched on. The Module 1000 switches over to cathode 2. Order new ion source. Cathode 1 is defective Defective ion source plug or cable. MSV board is defective. |
| W46 | Emission of cathode 2 cannot be switched on. | Signal MSIBE on MSV board is not active. Emission for cathode 2 cannot be switched on. The Module 1000 switches over to cathode 1. Order new ion source. Cathode 2 is defective Defective ion source plug or cable. MSV board is defective. |
| E47 | Emission on both cathodes cannot be switched on! | Signal MSIBE on MSV board is not active. Emission on both cathodes cannot be switched on! After having exchanged the ion source it must be possible to switch on both cathodes manually via the service menu. Both cathods are defective. Replace the ion source. Defective ion source plug. MSV board is defective. |
| W49 | Several specimens in succession are defective! Execute reference measurement. | Leak test device detects several defective specimens in succession. Check the setting, for which number of pieces the error is reported. Background signal has been increased very high. Repeat the reference measurement. |
| E50 | No communication with turbo pump. | No communication with drive electronic unit TC 600. Fuse F10 on wiring backplane has blown. Connector RS 485 on cross wiring backplane or electronic drive control TMH 071 nit plugged. Electronic drive control TC 600 defective, replace TMH 071 MC 68 is defective |
| E52 | Turbopump frequency is too low! | The speed of the turbomolecular pump TMH 071 is too low after a 5 min. starting period. Prepressure of TMH 071 is too high Turbo molecular pump TMH 071 is faulty. Electronic drive control TMH 600 is faulty. |
| W53 | Temperature of the electronic unit is too high! (55°C) | Ambient temperature is too high. Unfavourable placement of the leak test device. (heat accumulation) Fan failure Air filter very soiled; Defective temperature sensor |

| No. | Displayed Message | Description and possible solutions |
|-----|---|--|
| E54 | Temperature of the electronic unit is too high! (60°C) | Ambient temperature is too high. Unfavourable placement of the leak test device. (heat accumulation) Fan failure Air filter very soiled; Defective temperature sensor |
| W55 | Temperature of electronic unit is too low (<2°C). | Temperature sensor on the wiring backplane shows that $T < 2$ °C. Longer warm up period of the ext. of the ext. booster pump! Ambient temperature too low Temperature sensor is defective. |
| E56 | Inlet pressure p1 too low! | Output voltage Pirani p1 $U < 0.27$ V. Pirani Sensor p1 defective. Electronic unit of Pirani on E/A board defective. Cable connection defective. |
| E58 | Foreline pressure p2 too low! | Output voltage Pirani p2 $U < 0.27$ V; Pirani Sensor p1 defective. Electronic unit of Pirani on E/A board defective. Cable connection defective. |
| E60 | p2>10 mbar after 5 minutes since power on | p2 > 10 mbar after t > 5 minutes after switching on the leak test equipment. Ending pressure of the booster pump is too high. Leak in the high vacuum system of pre-vacuum connection. Fore-pump is faulty. Valve V2 does not open because the speed rate of 6 Hz for TMh 071 is not exceeded. Pressure measurement is incorrect |
| E61 | Emission failed. | Emission should be switched on. MSV subassembly indicates a fault. MENB emission current not within range. Both cathods are defective. Replace the ion source. Connector of ion source is not plugged in. MSV board is defective. |
| W62 | Flow through capillary to low. Possibly,leaks cannot be detected. | The intake pressure of the sniffer line is monitored in the sniffer mode. If the pressure drops below a minimum value, the flow through the capillaries is too low. The minimum value can be set within certain limits via the menu. The default value is 0.06 mbar. Filter is blocked in the filter tip Sinter filter is contaminated in the filter tip Capillaries are blocked by penetrating contamination. Lower pressure limit is too high. |
| E63 | Capillaries are broken | The intake pressure of the sniffer line is monitored in sniffer mode. If the pressure exceeds a specified maximum, the gas flow through the capillaries is too high. The maximum value can be set within certain limits via the menu. The default value is 2.0 mbar. Capillaries are broken or torn. Upper pressure limit too low |

| No. | Displayed Message | Description and possible solutions |
|-----|---|---|
| W64 | Pre-amplifier signal is too high. | In the most insensitive measurement range the pre-amplifier signal has exceeded 10 V for 10 s. Strong helium contamination of the high-vacuum system. The pre-amplifier is faulty. High contamination in the mass spectrometer. |
| E68 | TMP frequency too low! | TMP frequency of nominal speed dropped in sniffer mode. Sniffer not connected! Sniffer line leaky. Frequency converter is faulty. Replace TMH 071. |
| W69 | Signal difference between test leak and air too small! | Signal difference between test leak and $< 2 \times 10E-14$ A. Incorrect operation during calibration Test leak too low! Test leak is empty. |
| W70 | Supply voltage +/-15 V too low. | DC/DC converters on the MSV board generate too low output voltages. Fuse F3 on the MSV board is defective. DC/DC transformer on MSV board is defective. Jumpers for DC/DC transformer on the MSV board are incorrectly plugged. |
| W71 | Supply voltage +/-15 V too high. | DC/DC converters on the MSV board generate too high output voltages. DC/DC transformer on MSV board is defective. |
| E73 | Emission off (p2 too high) | The emission is switched off when the pressure is $p_2 > 22$ mbar If the pressure decreases after the intake valve has been closed, the leak test device goes back to the stand-by mode. Air penetration during the measuring mode. Polluted valves |
| W75 | Maximum of evacuation time of 100 mbar was exceeded. | The pressure limit of 10 mbar was not reached within the set evacuation time . Test sample has got a GROSS leak. The evacuation time is incorrectly adapted to the sample volume. |
| W76 | The maximum evacuation time until the measuring mode was exceeded. | The pressure limit of 0.4 mbar was not reached within the set evacuation time . Test sample has got a GROSS leak. The evacuation time is incorrectly adapted to the sample volume. |
| W77 | Peak not in Range | The signal maximum could not be detected within the mass calibration range. The signal maximum has shifted to mass range alignment limits. Incorrect basic setting of the anode voltage. Perform a manual mass calibration and reset the anode voltage via service menu . Leak rate signal was unstable during the mass calibration. Calibrate again. Wrong or incorrect test leak. Check internal test leak and repeat the calibration with the external test leak. |
| W78 | Differences of signal between open and closed test leak is too low. | Amplifier-voltage difference between the open and closed test leak is $\leq 2 \times 10E-14$ A. Internal test leak is defective. The external test leak valve is defective or not closed. |

| No. | Displayed Message | Description and possible solutions |
|-----|---|--|
| W79 | The test leak signal is too low. | The amplifier-voltage produced by the test leak is $\leq 2 \times 10E-14$ A. The test leak used for the calibration is too low! The external test leak valve is not open or defective. Internal test leak is defective. |
| W80 | Please re-calibrate the leak detector | The automatic request for calibration is activated and at least one of the following conditions is fulfilled: 30 minutes are passed since the test leak device was switched on. Temperature of the pre-amplifier has changed more by than 5°C since the last calibration. Mass alignment or operating mode were changed. The measuring time in test chamber operation was changed. |
| W81 | CAL Factor too low | The calculated calibration factor is outside the approved range (< 0.1). The old factor is retained. The internal test leak is defect. The entered leak rate for the internal test leak is too low. The conditions for calibration have not been maintained. |
| W82 | Calibration factor too high! | The calculated calibration factor is outside the approved range (< 10). The old factor is retained. The internal test leak is defect or empty. The entered test leak rate for the internal test leak is too high. The mass spectrometer is dirty and insensitive. The conditions for calibration have not been maintained. |
| W83 | All EEPROM parameter are lost! Please check your settings. | EEPROM on wiring backplane is empty and was initialized with default values. All customer parameters must be re-entered or redefined. If the warning appears again when switching on, the EEPROM cannot be written on the wiring level. EEPROM on wiring level is defective |
| W84 | EEPROM-Parameter initialises after software-update | Missing or changed parameters in the EEPROM and new software version number were detected. A software update was performed and one or more new parameters were detected. In this case, the message can be acknowledged. The parameter(s) were automatically added. |
| W85 | Lost EEPROM parameter! Please check the setting! | Defective or missing parameter detected in the EEPROM. The software version number did not change. If the warning occurs after restart again, the EEPROM cannot be written on the wiring backplane or is defect. EEPROM on wiring backplane is defective! The write access was interrupted. Check the settings and acknowledge the error message. |
| W86 | All I•STICK Parameters lost! Please check your settings! | I•STICK on wiring backplane is empty and was initialized with default values. All customer parameters must be re-entered or redefined. I•STICK not connected! I•STICK does not contain values. I•STICK is faulty! |

| No. | Displayed Message | Description and possible solutions |
|-----|---|--|
| W87 | Parameters are initialized in the I•STICK! Please check the settings! | Missing or changed parameters in the I•STICK and new software version number were detected. A software update was performed and one or more new parameters were detected. In this case, the message can be acknowledged. The parameter(s) were automatically added. |
| W88 | Parameters are lost in the I•STICK! Please check the settings! | Defective or missing parameter detected in the I•STICK. The software version number did not change. If the warning occurs after restart again, the I•STICK cannot be written on the wiring backplane or is defect. I•STICK on wiring backplane is defective! The write access was interrupted. Check the settings and acknowledge the error message. |
| E89 | Monitoring voltage F1,F2 | Voltage monitoring for fuses F1, F2 AD 24 B < 5,6 V. Fuse F1 interface board (SSK) defective. |
| E90 | Monitoring voltage F1,F2 | Voltage monitoring for fuses F1, F2 AD 24 B < 7.8 V. Fuse F2 interface board (SSK) defective. |
| W91 | P_ext smaller than p_A | Pressure in the sample drops below the value of p_A, although only the test chamber was pumped. Sample was leaky. Adaptation sample was leaky. Wrong setting for p_A. |
| W92 | Evacuation of sample takes too long . | Time t1 > as the set evacuation time t_A. Valve V30 does not open. Fore pump defective Test sample was leaky. Wrong time setting for t_A. Wrong setting for the evacuation pressure p_B. |
| W93 | Filling of the test sample with test gas takes too long. | Time t1 > as the set filling time for the sample t_C. Valve test gas inlet V33 does not open. Selected time for test gas inlet t_C too short. Selected Test gas filling pressure p_C to high. |
| W94 | Time to "Ultra" too long | Time t2 > than the time t_F to reach the measuring mode „Ultra“. Test chamber leaky! Sample is leaky. Wrong setting for time t_F (time until ready for measurement "Ultra"). |
| W95 | Discharge of test gas takes too long. | Time t1 > as the depressurizing time t_D. Test gas pump system defect. Valve V32 does not open. The selected time t_D for reaching the depressurizing pressure p_D too short. Selection of depressurizing pressure p_D wrong. Depressurizing pressure p_D > set end pressure after the depressurizing time t_D has expired. |

| No. | Displayed Message | Description and possible solutions |
|-----|--|---|
| W96 | Residual gas evacuates too slow. | Time t_1 > than the set evacuation time t_A . Valve V30 does not open. Fore pump defective Wrong time setting for t_A . t_A < than the evacuation time of residual gas. Wrong setting for the evacuation pressure p_B . Evacuation pressure not reached within the preset evacuation time (p_B < residual pressure of test gas). |
| W97 | Flooding of test sample takes too long . | Time t_1 > than the set flooding time. Flooding valve V31 defect. Wrong setting of the flooding time to reach the pressure p_A . (p_A = pressure of Gross leak). t_E < ventilation time Wrong setting of pressure p_A , which has to be reached within specified flooding time p_A > atmospheric pressure. |
| W98 | Leak rate not stable enough during the zero- delay time. | When reaching "Ultra", the readiness for measuring will be enabled for the function I•ZERO „activated“, when a stable leak rate signal appeared during the zero-delay time depending on the selected trigger. False adjustment of the zero-delay time t_B . Selected trigger 1 too low. Background in the test chamber is too high. |
| W99 | Pressure in the sample has dropped below p_E . | During the measurement time, the filling pressure of the sample dropped below the pressure drop trigger p_E . Wrong setting for the pressure drop trigger P_E . Gross leak on test sample. |

11 Ordering Information

| Description | Cat. no. |
|--|-------------------------------|
| Control Panel Desktop Operation | 551-100 |
| Control Panel Rack Installation | 551-101 |
| Connecting cable to control panel, 1 m | 551-103 |
| Connecting cable to control panel, 5 m | 551-102 |
| Sniffer line SL200 | 140 05 |
| Remote control <ul style="list-style-type: none"> – RC1000WL remote control, wireless – RC1000C remote control, non-wireless – Wireless transmitter (for the operation of a further leak test device) | 551-015 551-010 551-020 |
| Test chamber TC1000 | 551-005 |
| Set of plugs | 551-110 |

11.1 Service Centres World Wide

| | | | |
|-----------------------------|-----------------------------------|------------------------|------------------------------------|
| Algeria | jhj@agramkow.dk | Finland | jhj@agramkow.dk |
| Agramkow | Phone: +45 741 236 36 | Agramkow | Phone: +45 741 236 36 |
| Sonderborg | Fax: +45 744 336 46 | Sonderborg | Fax: +45 744 336 46 |
| Belarus | leakdetection.service@inficon.com | France | Christophe.Zaffanella@oerlikon.com |
| INFICON GmbH | Phone: +49 221 56788-112 | OLV France | Phone: +33 476 351 584 |
| Cologne | Fax: +49 221 56788-9112 | Orsay | Fax: +33 476 351 584 |
| Belgium | leakdetection.service@inficon.com | Germany | leakdetection.service@inficon.com |
| INFICON GmbH | Phone: +49 221 56788-112 | INFICON GmbH | Phone: +49 221 56788-112 |
| Cologne | Fax: +49 221 56788-9112 | Cologne | Fax: +49 221 56788-9112 |
| Brazil | fernandoz@prestvacuo.com.br | Hungary | adam.lovics@kon-trade.hu |
| PV Pest Vácuo Ltda. | Phone: +55 114 154 4888 | Kontrade | Phone: +36 23 50 38 80 |
| Santa de Parnaíba | Fax: +55 114 154 4888 | Budaörs | Fax: +36 23 50 38 96 |
| Bulgaria | leakdetection.service@inficon.com | India | asdash@hotmail.com |
| INFICON GmbH | Phone: +49 221 56788-112 | Dashpute | Phone: +91 22 888 0324 |
| Cologne | Fax: +49 221 56788-9112 | 400 064 | Fax: +91 22 888 0324 |
| Canada | reachus@vpcinc.ca | Ireland | reach.unitedkingdom@inficon.com |
| Vacuum Products Canada Ltd. | Phone: +905.672.7704 | INFICON | Phone: +44 1254 678 250 |
| Ontario | Fax: +905.672.2249 | Blackburn | Fax: +44 1254 698 577 |
| Central America | infoqro@meisa.com | Italy | davide.giovanetti@inficon.com |
| MEISA S.a. de C.V. | Phone: +52 44 22 25 42 80 | INFICON GmbH | Phone: +39 045 6 40 25 56 |
| Querétaro | Fax: +52 44 22 25 41 57 | Castelnuovo | Fax: +39 045 6 40 24 21 |
| China | reach.china@inficon.com | Israel | urimark@mark-tec.co.il |
| INFICON LTD | Phone: +852.2862.8863 | Mark Technologies Ltd. | Phone: +972 35 34 68 22 |
| Hong Kong | Fax: +852.2865.6883 | Kiriat Ono | Fax: +972 35 34 25 89 |
| INFICON LTD | Phone: +86.10.6590.0164 | Japan | reach.japan@inficon.com |
| Beijing | Fax: +86.10.6590.0521 | INFICON Co. Ltd. | Phone: +81.45.471.3396 |
| INFICON LTD | Phone: +86.20.8723.6889 | Yokohama | Fax: +81.45.471.3387 |
| Guangzhou | Fax: +86.20.8723.6003 | | |
| INFICON LTD | Phone: +86.21.6209.3094 | | |
| Shanghai | Fax: +86.21.6295.2852 | | |
| Czech Republic | filip.lisec@inficon.com | Korea | reach.korea@inficon.com |
| INFICON GmbH | Phone +420 734 331 758 | INFICON Ltd. | Phone: +82 312 062 890 |
| Pilsen | Fax: +420 604 203 037 | Sungnam city | Fax: +82 312 063 058 |
| Denmark | jhj@agramkow.dk | INFICON Ltd. | Phone: +82 312 062 890 |
| Agramkow | Phone: +45 744 336 36 | Suwon City | Fax: +82 312 063 058 |
| Sonderborg | Fax: +45 744 336 46 | INFICON Ltd. | Phone: +82 312 062 890 |
| Egypt | jhj@agramkow.dk | Cheonan City | Fax: +82 312 063 058 |
| Agramkow | Phone: +45 741 236 36 | Latvia | leakdetection.service@inficon.com |
| Sonderborg | Fax: +45 744 336 46 | INFICON GmbH | Phone: +49 221 56788-112 |
| Estonia | leakdetection.service@inficon.com | Cologne | Fax: +49 221 56788-9112 |
| INFICON GmbH | Phone: +49 221 56788-112 | Lithuania | leakdetection.service@inficon.com |
| Cologne | Fax: +49 221 56788-9112 | INFICON GmbH | Phone: +49 221 56788-112 |
| | | Cologne | Fax: +49 221 56788-9112 |

| | | | |
|--|--|---|--|
| Mexico MEISA S.a. de C.V. Querétaro | infoqro@meisa.com Phone: +52 442 225 42 80 Fax: +52 442 225 41 57 | Spain Leybold Optics Ibérica Barcelona | richard.cunill@leyboldoptics.com Phone: +34 93 66 60 778 Fax: +34 93 66 64 612 |
| Netherlands INFICON GmbH Cologne | leakdetection.service@inficon.com Phone: +49 221 56788-112 Fax: +49 221 56788-9112 | Sweden Agramkow Sonderborg | jhj@agramkow.dk Phone: +45 741 236 36 Fax: +45 744 336 46 |
| Norway Agramkow Sonderborg | jhj@agramkow.dk Phone: +45 741 236 36 Fax: +45 744 336 46 | Syria INFICON GmbH Cologne | leakdetection.service@inficon.com Phone: +49 221 56788-112 Fax: +49 221 56788-9112 |
| Poland VAK-POL & GAZ Sp. zo.o Pulawy | kamola@vakpol.com Phone: +48 60 23 15 212 Fax: +48 60 23 15 212 | Taiwan INFICON Company Limited Chupei City, HsinChu Hsien | Susan.Chang@inficon.com Phone: +886.3.5525.828 Fax: +886.3.5525.829 |
| Portugal INFICON GmbH Cologne | leakdetection.service@inficon.com Phone: +49 221 56788-112 Fax: +49 221 56788-9112 | Tunisia INFICON GmbH Cologne | leakdetection.service@inficon.com Phone: +49 221 56788-112 Fax: +49 221 56788-9112 |
| Republic of South Africa Vacuquip Randburg | vacuquip@hotmail.com Phone: +27 73 15 78 355 | Turkey Agramkow Sonderborg | jhj@agramkow.dk Phone: +45 741 236 36 Fax: +45 744 336 46 |
| Russia INFICON GmbH Cologne | leakdetection.service@inficon.com Phone: +49 221 56788-112 Fax: +49 221 56788-9112 | Ukraine INFICON GmbH Cologne | leakdetection.service@inficon.com Phone: +49 221 56788-112 Fax: +49 221 56788-9112 |
| Singapore INFICON PTE LTD. Singapur | reach.singapore@inficon.com Phone: +65.890.6250 Fax: +65.890.6266 | United Kingdom INFICON Blackburn | reach.unitedkingdom@inficon.com Phone: +44 1254 678 250 Fax: +44 1254 698 577 |
| Slovakia INFICON GmbH Pilsen | filip.lisec@inficon.com Phone +420 734 331 758 Fax: +420 604 203 037 | United Arab Emirates INFICON GmbH Cologne | leakdetection.service@inficon.com Phone: +49 221 56788-112 Fax: +49 221 56788-9112 |
| Slovenia Medivac Ljubljani | medivak@siol.net Phone: +386 15 63 91 50 Fax: +386 17 22 04 51 | USA Inficon Inc. East Syracuse, NY | service.usa@inficon.com Phone: +1.315.434.1167 Fax: +1.315.434.2551 |
| South America except Brazil MEISA S.a. de C.V. Querétaro | infoqro@meisa.com Phone: +52 44 22 12 36 15 Fax: +52 44 22 12 19 40 | Inficon Inc. San Jose, CA Inficon Inc. Austin, TX | Phone: +1.408.361.1200 Fax: +1.408.362.1556 Phone: +1.512.448.0488 Fax: +1.512.448.0398 |

INDEX

Fore-pump, refer to pump

A

| | |
|------------------|-----------------|
| Access control | 6-31 |
| Accessories | 3-6, 4-3 |
| air filter | 7-4 |
| Alarm delay | 6-17 |
| Alarms | 6-16 |
| Analogue output | 9-10 |
| ASCII | 6-24 |
| Audio Alarm Type | 6-17 |
| Auto Leak Test | 5-3, 6-16, 6-20 |
| Auto zero | 1-6 |

B

| | |
|----------------------------------|-----------|
| background | 6-3, 6-23 |
| Background definition Inlet Area | 6-23 |
| Backing Pump | 4-6 |

C

| | |
|--------------------------|------|
| Calibration | |
| • External automatic | 6-19 |
| • External manual | 6-19 |
| • internal | 6-9 |
| Calibration Factor | 6-30 |
| Calibration request | 6-28 |
| Clear | 9-4 |
| Clear Test | |
| • Log | 6-30 |
| Commander Funktionen | 6-21 |
| Commander mode | 5-4 |
| Connector kit | 3-7 |
| Contamination protection | 6-29 |
| Contrast | 6-16 |
| Control | |
| • PLC | |
| – Inputs and Outputs | 4-2 |
| Control location | 6-23 |
| Control panel | |
| • graphical | 4-2 |

| | |
|---------------|----------|
| Control Unit | 4-2, 6-2 |
| Control units | 3-3 |
| Cycle | 9-5 |

D

| | |
|------------------------------|------|
| Data | |
| • internal | |
| – view | 6-30 |
| • recorded | 6-30 |
| Date | 6-26 |
| Declaration of contamination | 8-1 |
| Device PIN | |
| • change | 6-31 |
| Dimensions | 9-1 |

E

| | |
|----------------------|------|
| Error list | |
| • view | 6-30 |
| Evacuate | 6-6 |
| Evacuation time | 6-29 |
| External Calibration | 6-10 |

F

| | |
|-----------------------------|------|
| Fan Filter | 6-27 |
| Flood filter | |
| • replace | 7-14 |
| Fore-vacuum | |
| • Refer to fore-vacuum pump | |
| Fore-vacuum pressure | 1-6 |
| Fore-vacuum pump | 3-1 |

G

| | |
|-------------|-----------|
| Gas Ballast | 9-7 |
| Gas ballast | 6-20, 9-4 |

H

| | |
|------------------------|-----|
| Helium background | |
| • internal | 1-6 |
| Helium filling station | 5-6 |
| Helium leak rate | 9-1 |

| | | | |
|---|--|---|--|
| I | | O | |
| <ul style="list-style-type: none"> I•STICK • interchange 7-13 Info 6-30 Interface boards • 3-2 7-12 Interfaces • RS232 4-4, 6-2 | | <ul style="list-style-type: none"> Open • Device 7-6 – Tools Operating fluid reservoir 7-5, 7-7 Ordering Information 11-1 | |
| L | | P | |
| <ul style="list-style-type: none"> Language 6-26 Leak rate • minimum detectable 1-7 Leak rate filter 6-26 Leak Test • refer to Auto Leak Test Leak Ware 6-24 loud speaker 6-16 | | <ul style="list-style-type: none"> Parameter • Save/Load 6-27 Part number 5-3 Partial flow 6-9 Partial Flow Mode 5-2 Partnumber 6-27 PIN 6-31 Pin Assignments 9-13 Pinpoint 6-17 PLC • in 9-13 • out 9-15 PLC inputs • define 6-25–6-26 PLC outputs • define 6-25 Pressure Gauge 4-3, 9-16 Pressure gauge • external 4-3, 6-25 Pressure limit • vacuum area 6-29 Pump • fore 7-2 Purge 6-20 | |
| M | | R | |
| <ul style="list-style-type: none"> Machine factor 6-22 Main Menu 6-15 Mains fuse • replace – Material 7-11 – Tool 7-11 Maintenance • after 1500 hours 7-4 • after 2 hours 7-5 • after 5000 hours 7-4 • TMH071 7-7 Maintenance history 6-30 Maintenance intervals 6-27 Mass 6-23 Mass alignment • Autotune 1-6 Measure 9-7 Measuring 6-7 Measuring time 5-3 Menu 1-7, 6-4 Menu-PIN • change 6-31 Mode 6-16 Monitoring 6-28 | | <ul style="list-style-type: none"> Rack • Installation 9-22 – Drawing Range selection • automatic 1-6 Recorder 9-10, 9-21 Recorder output • analogue 4-4 • Scaling 6-26 Recorder outputs 9-10 Reference measurement 5-4 | |

| | | | |
|----------------------|----------------|---------------------------------|-----------|
| Remote control | 4-2, 6-2 | time axis | 6-15 |
| RS232 Protocol | 6-24–6-26 | Touch | |
| Run-up | 6-1, 6-6 | • Display | 6-4 |
| Run-up time | 9-1 | Transient time | |
| | | • CAL | 6-27 |
| | | Trigger | 6-6 |
| | | Turbo-molecular | |
| | | • Refer to turbo-molecular pump | |
| | | Turbo-molecular pump | 3-1 |
| S | | U | |
| Save | | Units | 6-17 |
| • Parameter | 6-27 | | |
| Series error message | | V | |
| • Auto Leak Test | 5-3 | Vacuum diagram | 6-30 |
| Service Centers | 11-3 | Vacuum mode | 5-1 |
| Set of spare fuses | 7-10 | Vacuum settings | 6-20 |
| Setpoint | 6-18 | Valves | |
| Settings | 6-23 | • Supply | |
| • Miscellaneous | 6-26 | – external | 9-20 |
| • view | 6-30 | – internal | 9-19 |
| Sniffer line | 4-3, 4-7 | VENT | 6-3 |
| Sound volume | 6-17 | Ventilation | 4-7, 6-20 |
| standby | 6-6 | View | 6-15 |
| START | 6-3 | | |
| Status line | 6-6 | W | |
| STOP | 6-3 | Weight | 9-1 |
| Suction capacity | 5-1, 6-22, 9-1 | Working Modes | 5-1 |
| Supplied equipment | 3-6 | | |
| | | Z | |
| T | | zero | 6-3 |
| Technical Data | 9-1 | | |
| Test equipment | 4-6 | | |
| Test Log | 6-30 | | |
| Test sample | 4-6 | | |
| Time | 6-26 | | |



INFICON GmbH, Bonner Strasse 498, D-50968 Cologne, Germany

UNITED STATES TAIWAN JAPAN KOREA SINGAPORE GERMANY FRANCE UNITED KINGDOM HONG KONG

Visit our website for contact information and other sales offices worldwide. www.inficon.com

Dokument: jinb80e1-h (1011)