

Translation of the original operating instructions

BM1000

Bus-Modul

Catalog No.:
560-315, 560-316, 560-317, 560-318

from software version:
--



INFICON GmbH
Bonner Strasse 498
50968 Cologne, Germany

Table of Contents

1 About these instructions	4
1.1 Other associated documents	4
1.2 Target groups	4
2 Safety	5
2.1 Owner requirements	5
2.2 Operator requirements.....	5
2.3 Warnings.....	5
3 Shipment, Transport, Storage	7
4 Description	8
4.1 Construction of the bus module	8
4.2 Function	8
4.3 Technical data	9
5 Installation and removal	10
5.1 Mount the bus module and the DIN-TS35 top hat rail	10
5.2 Establish connections	10
5.3 Remove the bus module from the DIN-TS35 top hat rail.....	11
6 Decommissioning the device	12
6.1 Disposing of the device.....	12
6.2 Sending in the device	12

1 About these instructions

1.1 Other associated documents

- Operating instructions of the connected leak detector
- Protocol Descriptions, Document No. jira54

1.2 Target groups

This instruction manual is aimed at the operator of the remote control and at technically qualified specialists, with experience in the field of leak testing technology.

2 Safety

2.1 Owner requirements

Safety conscious operation

- ▶ Operate and install the device only in technically perfect working order and as specified, in a safety-conscious and hazard-conscious manner and in compliance with these instructions.
- ▶ Fulfill and ensure compliance with the following regulations:
 - Intended use
 - Universally valid safety and accident prevention regulations
 - International, national and local standards and guidelines
 - Additional device-related provisions and regulations
- ▶ Use only original parts or parts approved by the manufacturer.
- ▶ Keep this manual available at the operating site.

Personnel qualifications

- ▶ All work must be performed only by technically qualified specialists who have been trained on the device.
- ▶ Allow personnel in training to work on the device only under the supervision of technically qualified specialists.
- ▶ Make sure that the authorized personnel have read and understood these instructions and all other applicable documents (refer to "Other associated documents"), especially the information on safety, maintenance and repairs, before starting work.
- ▶ Define responsibilities, authorizations and supervision of personnel.

2.2 Operator requirements

- ▶ Read, observe and follow the information in these instructions and the working instructions created by the owner, especially the safety instructions and warnings.

2.3 Warnings



 **DANGER**

Imminent threat resulting in death or serious injuries



⚠ WARNING

Hazardous situation resulting in potential death or serious injuries



⚠ CAUTION

Hazardous situation resulting in minor injuries

NOTICE

Hazardous situation resulting in damage to property or the environment

3 Shipment, Transport, Storage

Shipment

Item	Quantity
Bus module	1
Operating instructions	1

- ▶ Please check the scope of delivery of the product for completeness after receipt.

Transport

NOTICE

Damage due to unsuitable packaging material

Transport in unsuitable packaging material can damage the device.

Transport the device only in the original packaging.

Keep the original packaging.

Storage

- ▶ Store the device taking into consideration the technical data, refer to Chapter 4.3, page 9.

4 Description

4.1 Construction of the bus module

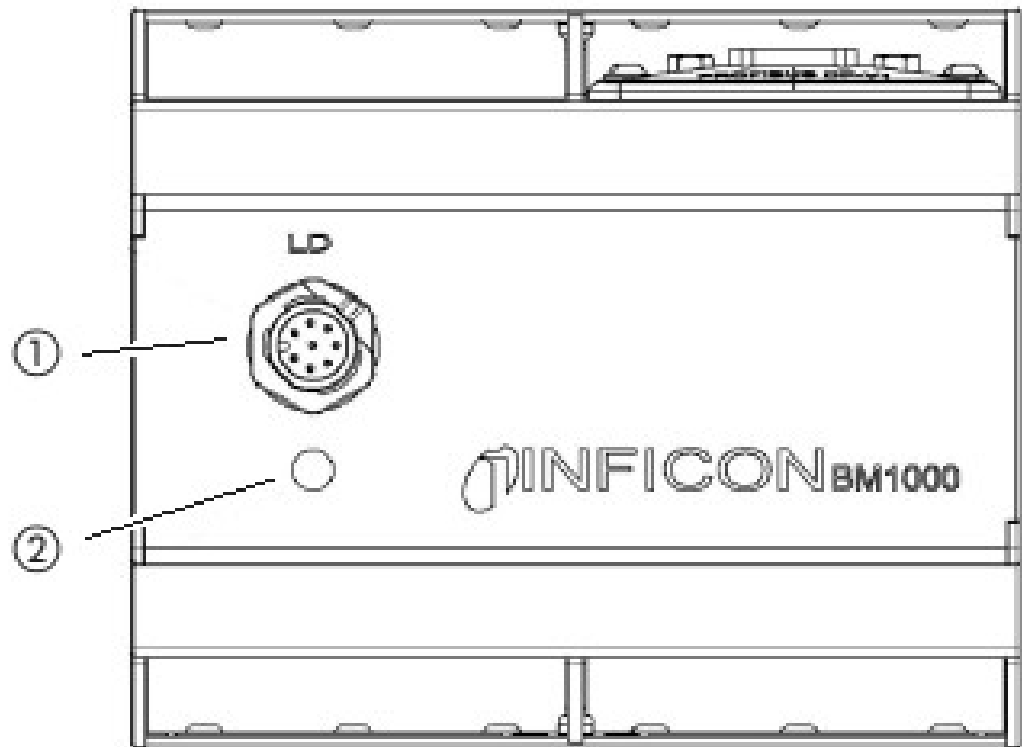

Fig. 1: Front view

1	Connection for the cable to the leak detector (LD)	2	Status LED Lights up green when the operating voltage is applied to the bus module.
---	--	---	---

4.2 Function

The bus module is a device interface between e.g. the MSB box of the mass spectrometer module LDS3000 and an external controller. The bus module BM1000 is available from INFICON in the following versions:

- 560-315 BM1000 PROFIBUS
- 560-316 BM1000 PROFINET
- 560-317 BM1000 DeviceNet
- 560-318 BM1000 EtherNet/IP

4.3 Technical data

Mechanical data

	BM1000 PROFIBUS
Dimensions (lxwxh)	107,6 mm x 89,7 mm x 76,6 mm

Electrical data

	BM1000 PROFIBUS
Protection class	IP20

Ambient conditions

	BM1000 PROFIBUS
Max. altitude above sea level	2000 m
Max. relative humidity above 40 °C	50%
Max. relative humidity from 31 °C to 40 °C	80% to 50% (linear abfallend)
Max. relative humidity to 40 °C	80%
Max. storage temperature	-20 °C - 60 °C
Pollution degree	II

5 Installation and removal

5.1 Mount the bus module and the DIN-TS35 top hat rail

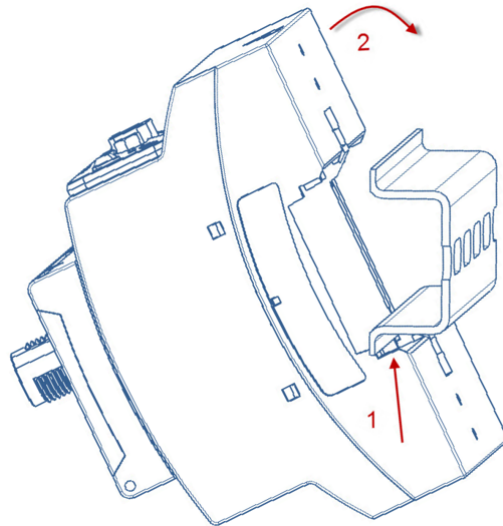

Fig. 2: Mounting of bus module

1. Hook device on top hat rail at bottom.
2. Press device onto top hat rail at top.

5.2 Establish connections

Connect the bus module with the leak testing unit

The bus module communicates via data cable with the leak testing unit and is supplied with voltage by the data cable.

✓ INFICON data cable

- 1 Connect the bus module (connection LD) via the data cable with the leak testing unit.
- 2 Connect the bus module with the external controller by means of the built-in field bus module.

The bus module is activated in the leak testing unit, e.g. the MSB box of the LDS3000, see the leak testing unit manual.

Communication with field bus master

For information on establishing communication with the Field bus master, see Interface protocols, jira54 and kirb43.

5.3 Remove the bus module from the DIN-TS35 top hat rail

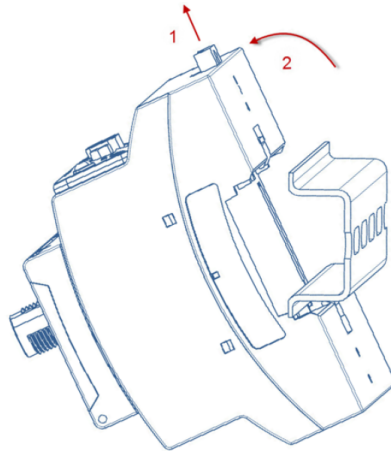

Fig. 3: Removing the bus module

1. Use the flat-tip screwdriver to pull out the locking device.
2. Pull the device off of the top hat rail.

6 Decommissioning the device

6.1 Disposing of the device

The device can either be disposed of by the operator or be sent to the manufacturer. The device consists of materials that can be recycled. This option should be exercised to prevent waste and also to protect the environment.

During disposal, observe the environmental and safety regulations of your country.

6.2 Sending in the device



WARNING

Danger due to harmful substances

Contaminated equipment endanger those who come into contact with .

- ▶ Fill in the declaration of contamination completely.
- ▶ Attach the declaration of contamination on the outside of the packaging.

The declaration of contamination is a legal requirement and serves to protect our employees. We send devices, which are sent without a completed declaration of contamination back to the sender.

