

Single stage side channel  
vacuum pump / compressor  
**EVSC-S57B3**

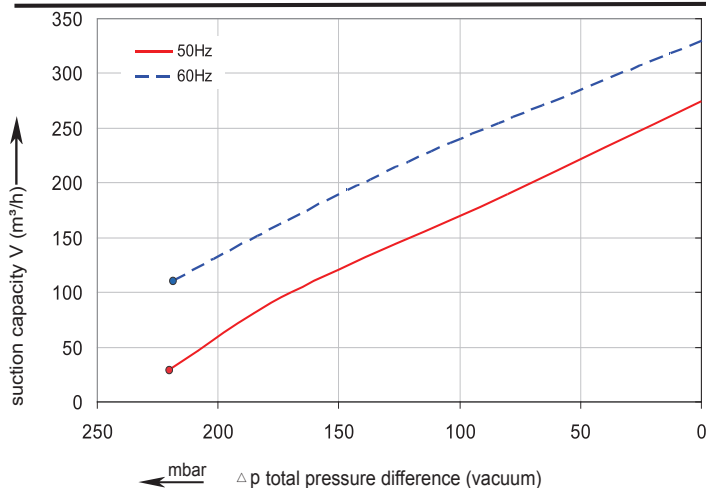

Performance curve for Vacuum pump



Performance curve for Compressor

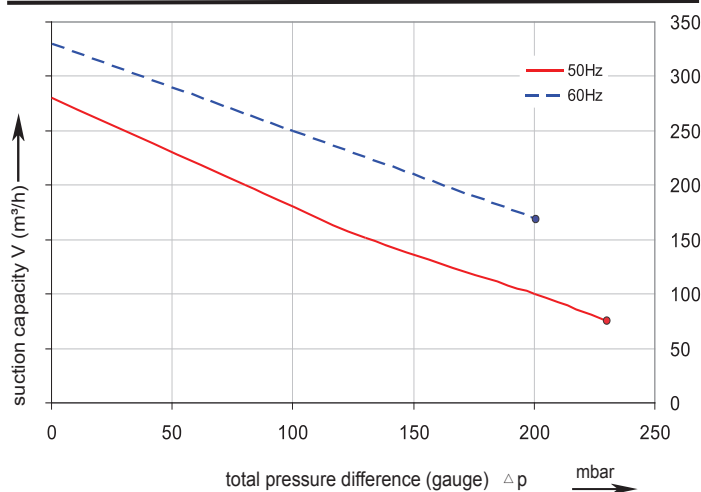

Technical Data

TYPE EVSC-S57B3

		50 Hz	60 Hz
Motor power	kW	2,2	2,55
Maximum airflow	m³/h	280	330
Ultimate pressure	mbar	+230	+200
Ultimate vacuum	mbar	-220	-220
Input voltage 3 phase Δ	V	200-260	230-290
Input voltage 3 phase Y	V	350-450	400-500
Input current Δ	A	8,2	8,1
Input current Y	A	4,65	4,65
Noise level	dB(A)	65	71
Weight	kg	26	26
Connection inlet	G(BSP)	2"	2"
Connection outlet	G(BSP)	2"	2"

Ordering Information TYPE EVSC-S57B3

EVSC-S57A3	3ph AC	141357
Other voltages/frequencies		Upon request

Accessories

Vacuum/pressure relief valve	See page 123
Vacuum inline dust filter	140036
Compressor suction filter	140026
Set of feet for horizontal positioning	140011

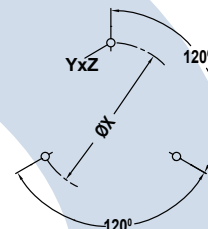
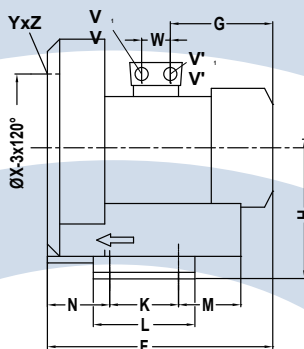
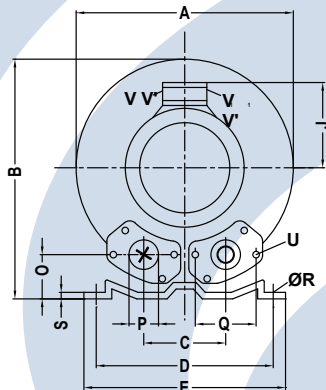

Type	Phases	A	B	C	D	E	F	G	H	J	K	L	M	N	O	P	Q	ØR	S	U	V	V	V <sub>1</sub>	V <sub>2</sub>	YxZ	X-Holes	ØX
EVSC-S57B3	3~	334	337	120	260	295	392	218	175	128	115	155	98	104	48	G2	83	14	4	M8x17	M25x1.5	M16x1.5	-	-	M8x20	0°/120°/240°	200