



**Eurovacuum
Installations and
Operating manual
EVCP Series
Compressors
Models:
0105 till 0155**

Single Stage Claw Compressors



Eurovacuum EVCP Series

Dry Running Claw Compressors

Eurovacuum Company is offering its various products to meet industrial needs.

Eurovacuum Company is founded in 2006, with over 30 year experiences in the vacuum & Compressor Industry its founders have been putting their best efforts continuously to produce high quality Dry Running Claw Vacuum Pumps & Compressors, with diverse range of capacity for use in printing, pick & place, packaging, CNC Routing, vacuum lifting, Central systems and General vacuum & Compressor or other industrial application.

Advantages to the User

- High pumping speed
- The pumping chamber is oil free
- Air-cooling, no water required
- Low space requirement, easy to install
- Very little maintenance is needed
- Maintenance-friendly
- Compact design
- Over-Pressure Valve
- The two claws are running contact free
- Direct drive, Design requires no belts
- Wide range of accessories available for easy adaptation

Eurovacuum

Head office
Oostpolderweg 7
2841DA Moordrecht
The Netherlands

Tel. +31-(0)854890993
info@eurovacuum.eu
<http://www.eurovacuum.eu>

Contents



It is mandatory that these operating instructions be read and understood prior to the Compressor installation and start-up.

1.0 INSTALLATION

- 1.1 General description
- 1.2 Unpacking
- 1.3 Location
- 1.4 Power Requirements
- 1.5 Pressure Connections
- 1.6 Oil Filling on Gear box

2.0 SAFETY

- 2.1 General Notices
- 2.2 Warning Label and explanation
- 2.3 Location of Labels

3.0 OPERATION

- 3.1 Start-up
- 3.2 Stopping the compressor
- 3.3 Ambient operating conditions & limits

4.0 MAINTENANCE

- 4.1 Compressor Gear Lube Oil (level / type & quantity / change)
- 4.2 Inlet Filter
- 4.3 Maintenance Chart

5.0 PROBLEM SOLVING

6.0 TECHNICAL DATA



INSTALLATION AND OPERATING MANUAL

This manual is written to cover following contact-less operating claw type compressor. The model number is stamped into the nameplate with serial number: EVCP-0105 & 0155.

Please identify the model number and serial number when ordering parts.

1.0 INSTALLATION

1.1 General description

These EVCP compressors are dry and contactless machines, enclosed in acoustic sound shield and designed to have cooling air passed through the sound shield by fan. The warm air is exhausted through the vent. The EVCP is constructed in modular construction consisting of two compartments: pumping and gear chambers separated by using labyrinth seals. In the pump chamber, as two rotary claws rotate in opposite direction, the air sucked in, shall be compressed and discharged under pressure. In the gear chamber (box), two gears for synchronizing of claws rotation will be located with oil lubrication. For reduction of the noise, inlet silencer shall be installed in compressor inlet side. For a protection of overload, a pressure safety valve or regulating valve is installed in exhaust. The compressors are directly driven by a flanged motor via a coupling.

1.2 Unpacking

Inspect the box and compressor carefully for any signs of damage incurred in transit. Since all compressors are ordinarily shipped EXW from our factory or regional warehouse, such damage is the normal responsibility of the carrier and should be reported to them.

The compressor is bolted to the skid with studs that are connected through the rubber feet of the compressor. Remove the nuts from the underside of the crate and remove the pump. Unscrew the studs from the rubber feet.

The inlet and exhaust of the compressor are covered with plastic caps to prevent dirt and other foreign substances from entering the compressor. Leave these caps in place until you are ready to pipe the compressor to your equipment.

1.3 Location

Install the compressor in a horizontal position on a level surface so that the compressor can be evenly supported on its rubber feet. Leave 30 ~ 45 cm of access around the compressor to allow proper cooling. Also, adequate ventilation must be provided for the cooling of the compressor and motor. Allow access to the oil sight glass in order to inspect the oil level regularly, and the oil fill and oil drain port for easy service.

1.4 Power Requirements

A schematic diagram for the electrical motor terminal connections is located in the junction box of the motor or on the motor nameplate. Typical wirings for Three Phase Motors are as below:

Wiring Scheme- Three Phase Motor

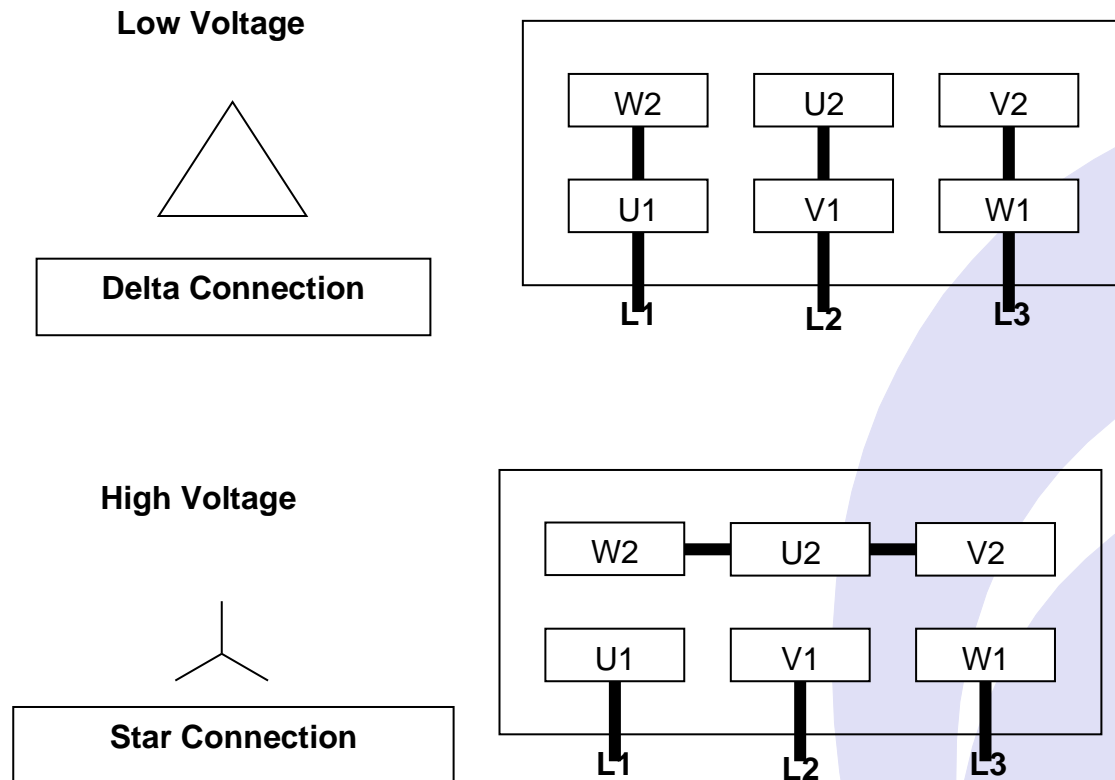

The motor must be connected according to the electrical codes through a fused switch in order to protect the motor against electrical or mechanical overload conditions. The overload of the motor starter must be set at a level equal to the full load motor current listed on the motor nameplate.

If the compressor is supplied with a motor starter, it is preset at the factory according to customer specifications. It is advisable to check that these settings are in line with the voltage at your location. If the voltage is different, please contact Eurovacuum for motor and starter information.

Correct direction of rotation is marked by an arrow on the motor fan housing and is counterclockwise when looking at the motor from the motor's fan side.

After electrical connections have been made, the rotation of the motor should be checked. If backward, reverse any two leads of the three at the power connection.



Eurovacuum

1.5 Pressure Connections

Use a pipe size that is at least the size of the compressor outlet connection. Smaller pipe lines result in a reduced compressor capacity.

Compressors operating in parallel on a common main line should have a manual or automatic operated shut-off valve or positive action check valve, installed in the pressure line. Remove the plastic protective cap from the discharge port prior to connection of compressor to the system. Should process gas contain dust or other foreign particles, a suitable in line (inlet) filter should be connected to the inlet port. Consult Eurovacuum for recommendations.

The following thread sizes are standard on the pumps (NPT thread is available upon request)

<u>Compressor Model</u>	<u>Inlet Size</u>	<u>Exhaust Size</u>
EVCP-0105 & 0155	G 1-1/2"	G 1-1/2"

1.6 Oil Filling on Gear Box

After level installation and correct rotation has been established, check the oil level of the compressor through the oil level glass and fill through the oil fill port if needed.

Oil level should be over 3/4 position on the oil sight glass as shown on the label.



We highly recommend Eurovacuum gear oil or equivalent oils. The use of an alternative oil may result in losing the warranty on the compressor.

- **Eurovacuum Gear Oil - 1 liter - Art.No.: 100500**

The following table gives the approximate quantities of oil required for each model.

<u>Compressor Model</u>	<u>Capacity (ltr)</u>
EVCP-0105 & 0155	0.5

Do not add fill oil with compressor running! Do not overfill.

2.0 SAFETY

Please read the following safety notice carefully before operating the compressor.

2.1 General Notices

- Understand fully this installation and operating manual before operation.
- Another person except authorized operator should not operate the compressor
- When the compressor is not properly working, it should be stopped immediately.
- Eurovacuum shall have no liability for any accident and failure arising from no compliance with instructions in this manual.

2.2 Warning labels and its explanation

Following warning labels are shown and attached on EVCP series compressors

2.2.1 Read and Understand a manual:

Read and understand operator's manual before using this machine

2.2.2 Burn Hazard:

Hot surface. Do not touch.

2.2.3 Loud noise Hazard

Loud noise hazard. Ear protection must be worn.

2.2.4 Hazardous Voltage:

Disconnect power before opening. Contact causes severe electrical shock



2.3 Location of the labels

The labels of 2.2.1 Read and Understand a manual, 2.2.2 Burn Hazard, and 2.2.3 Loud noise Hazard shall be shown on the top of sound shield of the compressor.

The label of 2.2.4 Hazardous Voltage shall be shown on the cover of motor's terminal box

3.0 OPERATION

3.1 Start-up

Check rotation of the motor as described in paragraph 1.4 Power Requirements.

Fill the compressor with oil as described in paragraph 1.5 - Oil Filling

Run the compressor for a few minutes and then shut down. Check the oil level again and make sure the oil level is 1/2 position of oil sight glass. Add oil though oil fill port, if necessary. Gear box oil should only be added when the compressor is off

3.2 Stopping the compressor

To stop the compressor, turn off the power.



3.3 Operating Conditions and Limits

The EVCP-Series are designed to run below set pressures according to the motor power for continuous operation. Operation over maximum pressure level may result in failure of and severe damage to the machine. Pressure Regulator installed in outlet flange is set at maximum allowable pressure (see the table for set of pressure) at factory.

The pressure can be adjusted by turning the stud of pressure regulating valve on the top of valve. The regulating valve or safety valve is set at permissible operating pressure and will be opened to discharge the pressure if the compressor runs over the setting pressure for a safety operation.

Caution: Do not run the compressor without regulating valve or safety valve. Do not set the regulating valve or safety valve at over permissible pressure. The compressor may be damaged severely.

The standard version is for use of dry air only, and may not be used in hazardous areas. Handling of humid air or gases containing aggressive chemicals is possible only with specially configured units. Consult Eurovacuum for assistance.

Also it is recommended for operating personnel who is working near the compressor to wear ear protectors. If noise below the designed dBA is required, an external sound enclosure can be added to the system, provided adequate ventilation is provided.

The ambient and suction air temperature must be between 5 and 40 °C

Caution: Any non-compliance may lead to severe injury to persons and damage to the compressor.

4.0 MAINTENANCE

EVCP-Series compressors require very little maintenance. To ensure optimum performance, the following maintenance steps should be followed:

4.1 Compressor Lube Oil

4.1.1 Gear Oil Level

Check the oil level on monthly basis. Under normal circumstances it should not be necessary to add oil between oil changes. A significant drop in oil level means there is an oil leak. Please check the O-rings, drain plug or oil sight glass.

Check the oil level only when the compressor is shut off. Replenish oil if it drops below bottom position of the sight glass.

Caution: Do not add oil while the compressor is running, since hot oil can escape from the oil fill port.

4.1.2 Gear Oil Type and Quantity

See section 1.5 - Oil Filling - for details on oil type and quantity



4.1.3 Oil Change

Under normal ambient conditions with proper Gear Oil, it is recommended to change the oil every 10.000 operating hours. It is necessary to make the first oil change between 500 ~1000 operating hours.

Caution: If different brand oil is being filled, the old oil must be drained completely from the gear box.

4.2 Inline (inlet) Filter

Check inline (inlet) filter on a weekly basis. The filter cartridge should be cleaned or replaced when dirty. Consult Eurovacuum or service agent for replacement element information.

Caution: Depending on the mounting position of the filter, be careful not to allow accumulated foreign material to fall in the pump suction inlet when removing the filter cartridge. Horizontal filter installation is recommended to prevent this.

4.3 Maintenance Chart

Weekly: Check inline inlet filter element. More often if high particulates in inlet stream.

Monthly: Check the oil level, Protective Mesh.

Semi-Annually: Check cooling fan and coupling.

Annually: Check Bearings/ Shaft Seals, More frequently if operated at ambient temperature exceeding 20°C.

Every 5000 operating hours: Change the gear oil



Inspection hole with G1" plug: Check the coupling and its insert, and fan through this hole regularly. (An endoscope or WireCam can be used with Smart Phone software)

5.0 PROBLEM SOLVING

5.1 Problem

Compressor does not reach capacity.

5.1.1 Possible Cause

Inlet screen (mesh) of the inlet filter clogged with debris.

Remedy : check inlet filter element and clean screen (mesh) by compressed air or wash it.

5.1.2 Possible Cause

Pipe work is too long or small.

Remedy : Use the bigger diameter pipe and shorten the lines length if possible.



Eurovacuum

5.2 Problem

Compressor runs over set pressure.

5.2.1 Possible Cause

Pressure Regulator or Safety Valve set over the set point, or is out of order.

Remedy : Set the point again or replace it with new one.

5.3 Problem

Compressor does not reach the set pressure.

5.3.1 Possible cause

Leak on the compressor or system.

Remedy : Check the leak on the compressor or system.

5.4 Problem

Compressor runs very noisy.

5.4.1 Possible Cause

Contamination of the claws or chamber.

Remedy : Clean the pumping chamber and the rotary claws.

5.4.2 Possible Cause

Coupling insert is worn.

Remedy : replace coupling insert in motor/compressor coupling.

5.4.3 Possible Cause

Bearing noise.

Remedy : replace bearings or call service agent for service or exchange program.

5.4.4 Possible Cause

Pressure regulator or safety valve noise.

Remedy : replace Pressure regulator or Safety valve.

5.5 Problem

Compressor will not start.

5.5.1 Possible Cause

Supply voltage is not proper or is overloaded. Motor starter overload settings are too low or improper; fuses are burned; wire size is too small or too long causing a voltage drop.

Remedy : check voltage supply; overload settings in motor starter for size and settings according to motor nameplate. Install proper size wire. If ambient temperature is high, use the next larger size overloads, or adjust settings 5% above motor nameplate value

Remedy : turn compressor fan by hand. If it will not turn, remove motor from Compressor and check motor and compressor separately. Repair or replace if needed or call service agent for service or exchange program.



Eurovacuum

5.6 Problem

Compressor is running too hot abnormally.

5.6.1 Possible cause

Not enough air ventilation to compressor.

Remedy : Make certain a sufficient amount of fresh air is supplied to the compressor.

5.7 Problem

Compressor will not operate (seized up).

5.7.1 Possible cause

Rotary Claws, Bearings or Gears stuck on.

Remedy : Call service agent for service or exchange program.

6.0 TECHNICAL DATA

Technical Data		EVCP-0105		EVCP-0155	
		50 Hz	60 Hz	50 Hz	60 Hz
Pressure flow rate	m ³ /h	100	120	150	180
Maximum pressure cont.	bar	0,8/1,4/2,2	-/1,4/2,2	1,2/2,0	1,2/2,0
Motor power	kW	3,0/4,0/5,5	-/5,5/7,5	5,5/7,5	7,5/9,2
Nominal speed	rpm	2850	3450	2850	3450
Noise level	dB(A)	79	80	80	82
Oil capacity (Gear box)	ltr	0,5	0,5	0,5	0,5
Admissible ambient temp	°C	5 to 40	5 to 40	5 to 40	5 to 40
Connection	Inlet	G(BSP)	1-1/2"	1-1/2"	1-1/2"
	Outlet	G(BSP)	1-1/2"	1-1/2"	1-1/2"
Weight approx.	Kg	139	142	142	150

