



EUROVACUUM EV-LX218

Robust high-performance leak detector at a fair price



OUTSTANDING PERFORMANCE AT A GREAT PRICE.

The high-performance EUROVACUUM EV-LX218 leak detector features reliable technology together with low investment costs. With proven components produced in Europe, top-quality performance is possible at a competitive price.

Leak detection is easier than ever before with the EV-LX218's simple installation and operation. The high suction capacity of the EV-LX218 results in extremely short testing times. This increases your productivity with simultaneous cost efficiency.

EUROVACUUM EV-LX218 Advantage:

Competitive price thanks to standard components and direct distribution channels

Highest degree of availability and reliability, even after long periods of use, with proven vacuum technology components such as mass spectrometers, pumps and valves

Very short measuring times due to high suction capacity

Detection of the smallest leaks, even in environments contaminated by helium, with an intelligent stainless steel vacuum system

The highest quality in your production or service application guaranteed by high-precision measuring technology

Easy operation and installation, with no training required

Robust and versatile, it can be used even in the harshest production environments

Simple operation, flexible system integration and leak testing methods.

The EUROVACUUM EV-LX218 leak detector offers many advantages for particularly fast and easy vacuum leak testing. With its robust, modular design and additional accessories, the EV-LX218 offers the greatest flexibility and reliability.



Easy-to-use display
It's easy to operate and features a large graphic display for quick assessment.



Interfaces
EV-LX218 has a wide variety of interfaces and connections to expand its capabilities.



Different leak testing methods
Suitable for every application.



High application flexibility due to EV-LX218 variants:



Diaphragm pump
For oil-free systems and processes.



Oil-sealed rotary vane pump
For General Industrial application, where robustness is required.



Module
Without forepump, for easy and affordable system integration.

EUROVACUUM EV-LX218 Accessories:



Remote control
Compatibility to remote control RC1000 for wireless operation.



Sniffer line 3, 5, 10 m
For the sniffing leak testing method.

EUROVACUUM EV-LX218

ORDER INFORMATION BASIC UNIT

EV-LX218 WET

230V 50Hz version	8200-000
115V 60Hz version	8200-001
100V 60Hz version	8200-005

EV-LX218 DRY

230V 50Hz version	8200-002
115V 60Hz version	8200-003

EV-LX218 MODULE

100V-250V 50/60 Hz	8200-004
--------------------	----------

TECHNICAL DATA

Lowest detectable leak rate for He (according to AVS 2.1)	$< 5 \times 10^{-13} \text{ Pa m}^3/\text{s}$
Ion source	Two long-life iridium filaments, yttrium-oxide coated (three-year warranty)
Testing method	Vacuum and sniffer leak detection
Detectable gases	^4He , ^3He , H_2
Internal He test leak	$10^{-8} \text{ Pa m}^3/\text{s}$
Leak rate display	$10^{-13} - 0.1 \text{ Pa m}^3/\text{s}$
Time to operation	3 min.
Response time	0.5 s
Suction capacity: He	2.5 l/s
Connecting flange	DN 25 ISO-KF
Inlet pressure, max.	25 mbar
Ambient temperature	+10°C to +35°C in operation
Input: analog	Compact gauge
Input: digital	Start/stop, zero, calibration
Interface	RS-232-C, RS-485
Output: analog	Leak rate signal 2 x 0-10 V, lin/log
Output: digital	Ready to start, ready to measure, leak, error, partial flow valve
Relay: switch voltage	2 x 230 V AC
Relay: switch current	3 A

ORDER INFORMATION ACCESSOIRES

Sniffer line 3m	551-300
Sniffer line 5m	551-301
Sniffer line 10m	551-302
Remote control with cable (RC1000)	551-010
Remote control wireless (RC1000)	551-015

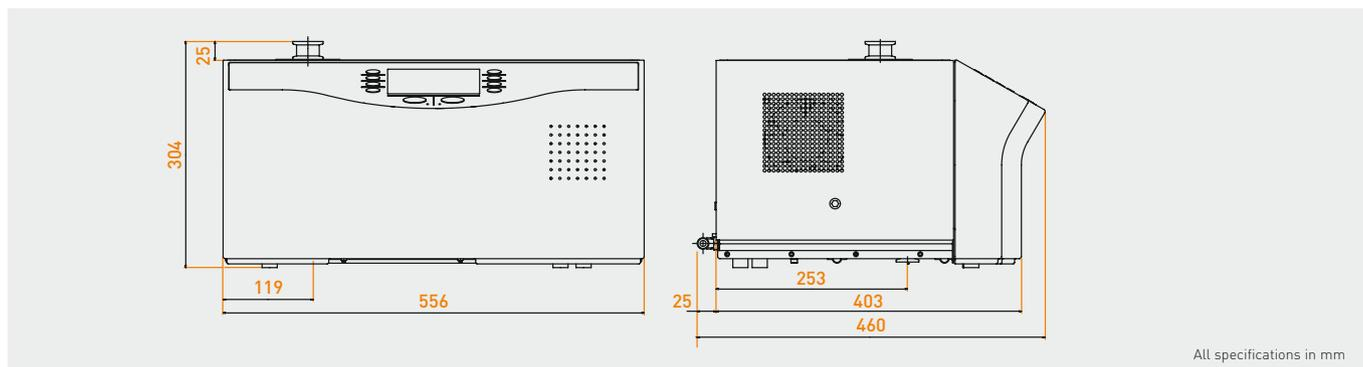

All specifications in mm